

# An Introduction To Network Science

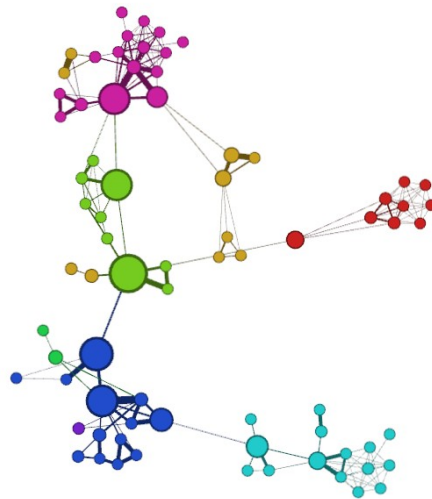

**Pedro Ribeiro**  
(DCC/FCUP & CRACS/INESC-TEC)

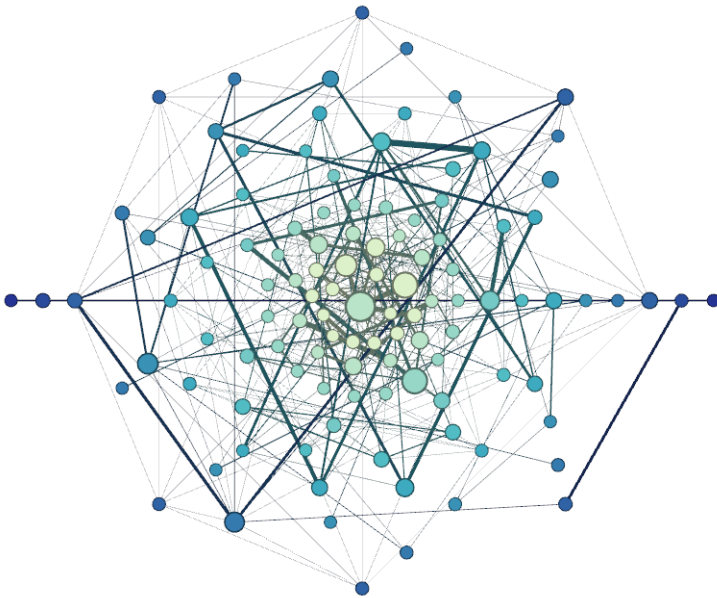

# **Motivation and the “small world” phenomenon**

# Planet Earth





# 8 Billion Humans





**How many  
“degrees”  
of separation?**

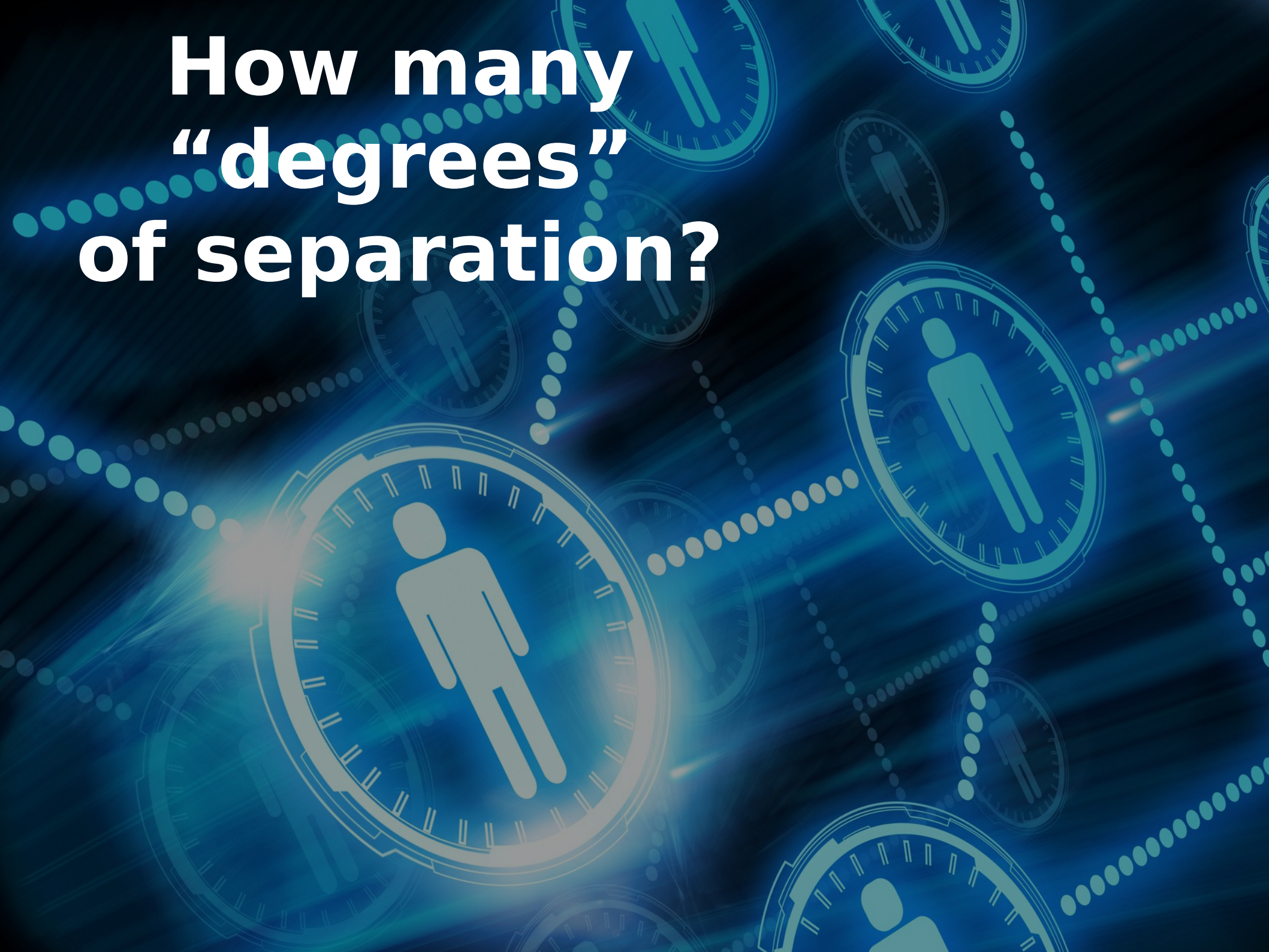





1929

Frigyes Karinthy

“If you choose a person out of the 1.5 billions of our planet, I bet that using no more than **five** individuals, one of them my acquaintance, I could contact the person you chose, using only the list of acquaintances of each one”

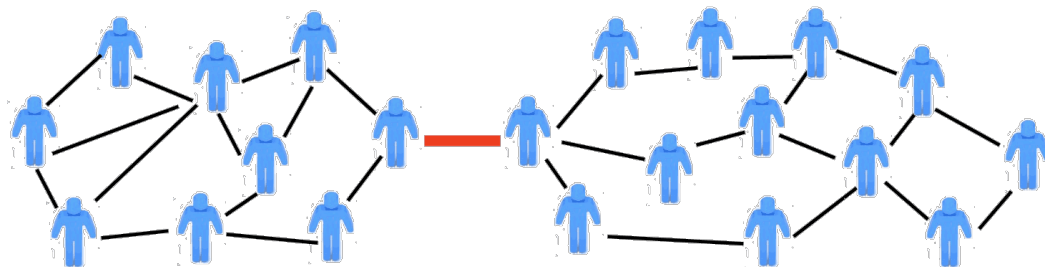



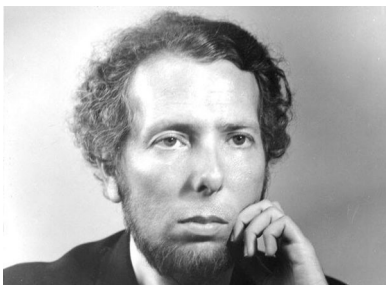

1969

# Stanley Milgram

- People chosen at random on a US State
- Request to send a letter to a given final person in another state :
  - If you know the final person, send directly to him
  - If not, send to someone you think it is more likely to know him

## An Experimental Study of the Small World Problem\*

JEFFREY TRAVERS

Harvard University

AND

STANLEY MILGRAM

The City University of New York

*Arbitrarily selected individuals ( $N=296$ ) in Nebraska and Boston are asked to generate acquaintance chains to a target person in Massachusetts, employing "the small world method" (Milgram, 1967). Sixty-four chains reach the target person. Within this group the mean number of intermediaries between starters and targets is 5.2. Boston starting chains reach the target person with fewer intermediaries than those starting in Nebraska; subpopulations in the Nebraska group do not differ among themselves. The funneling of chains through sociometric "stars" is noted, with 48 per cent of the chains passing through three persons before reaching the target. Applications of the method to studies of large scale social structure are discussed.*





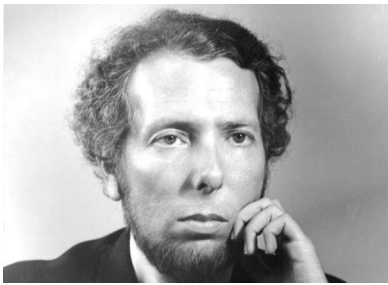

1969

# Stanley Milgram

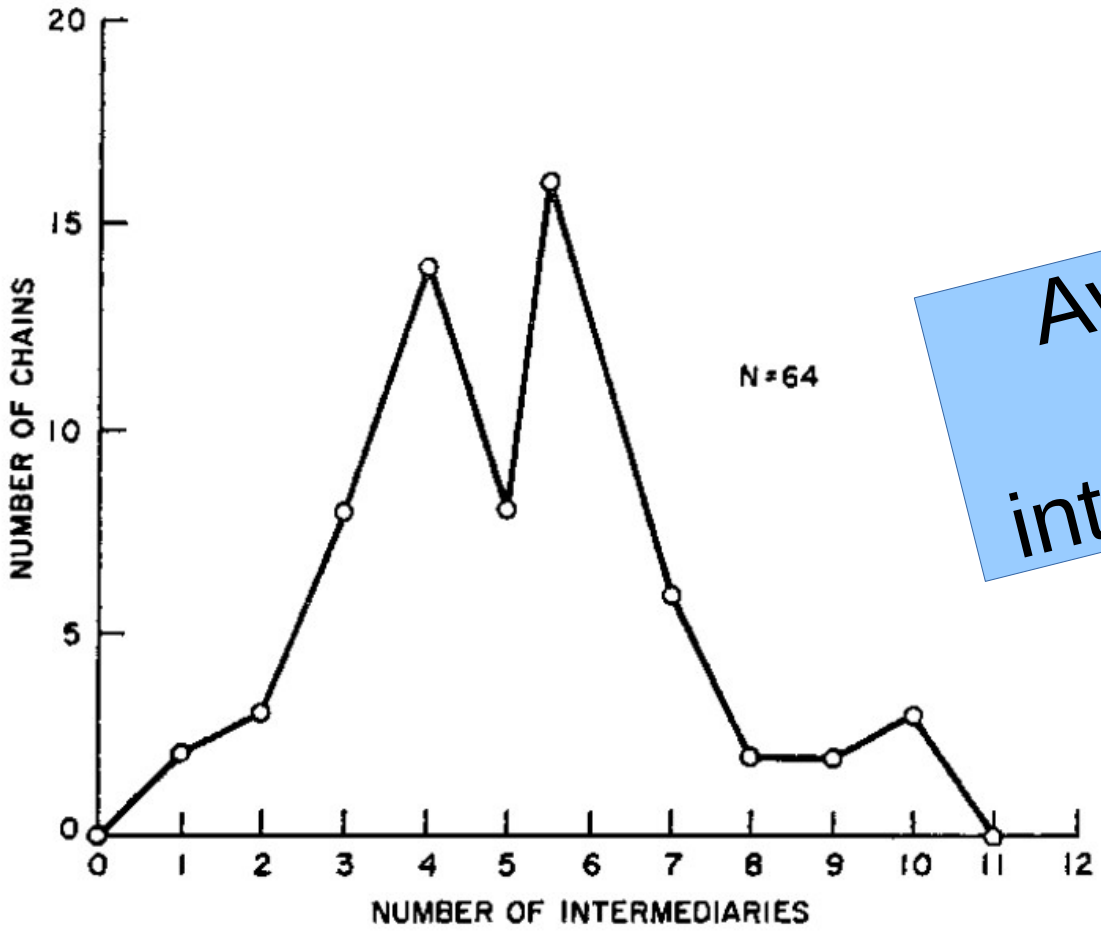

Average between 5.5 and 6 intermediate persons

FIGURE 1  
*Lengths of Completed Chains*





2003

# “Small World” Project

- More than 20,000 chains of emails to 18 persons of 13 countries

Median estimated between 5 and 7

## An Experimental Study of Search in Global Social Networks

Peter Sheridan Dodds,<sup>1</sup> Roby Muhamad,<sup>2</sup> Duncan J. Watts<sup>1,2\*</sup>

We report on a global social-search experiment in which more than 60,000 e-mail users attempted to reach one of 18 target persons in 13 countries by forwarding messages to acquaintances. We find that successful social search is conducted primarily through intermediate to weak strength ties, does not require highly connected “hubs” to succeed, and, in contrast to unsuccessful social search, disproportionately relies on professional relationships. By accounting for the attrition of message chains, we estimate that social searches can reach their targets in a median of five to seven steps, depending on the separation of source and target, although small variations in chain lengths and participation rates generate large differences in target reachability. We conclude that although global social networks are, in principle, searchable, actual success depends sensitively on individual incentives.

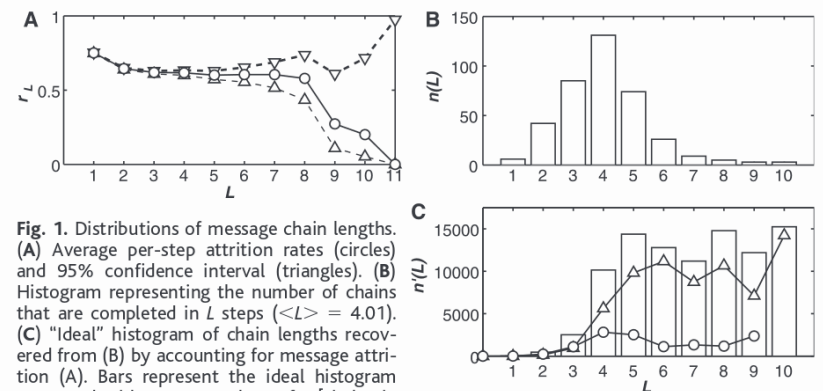
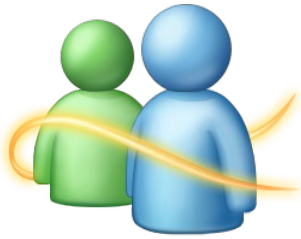

Fig. 1. Distributions of message chain lengths. (A) Average per-step attrition rates (circles) and 95% confidence interval (triangles). (B) Histogram representing the number of chains that are completed in  $L$  steps ( $\langle L \rangle = 4.01$ ). (C) “Ideal” histogram of chain lengths recovered from (B) by accounting for message attrition (A). Bars represent the ideal histogram recovered with average values of  $r$  [circles in (A)] for the histogram in (B); lines represent a decomposition of the complete data into chains that start in the same country as the target (circles) and those that start in a different country (triangles).



2008

# Microsoft Messenger

- 30 billion conversations between 240 million persons

## Planetary-Scale Views on a Large Instant-Messaging Network

Jure Leskovec\*  
Carnegie Mellon University  
jure@cs.cmu.edu

Eric Horvitz  
Microsoft Research  
horvitz@microsoft.com

Global Average: 5.6

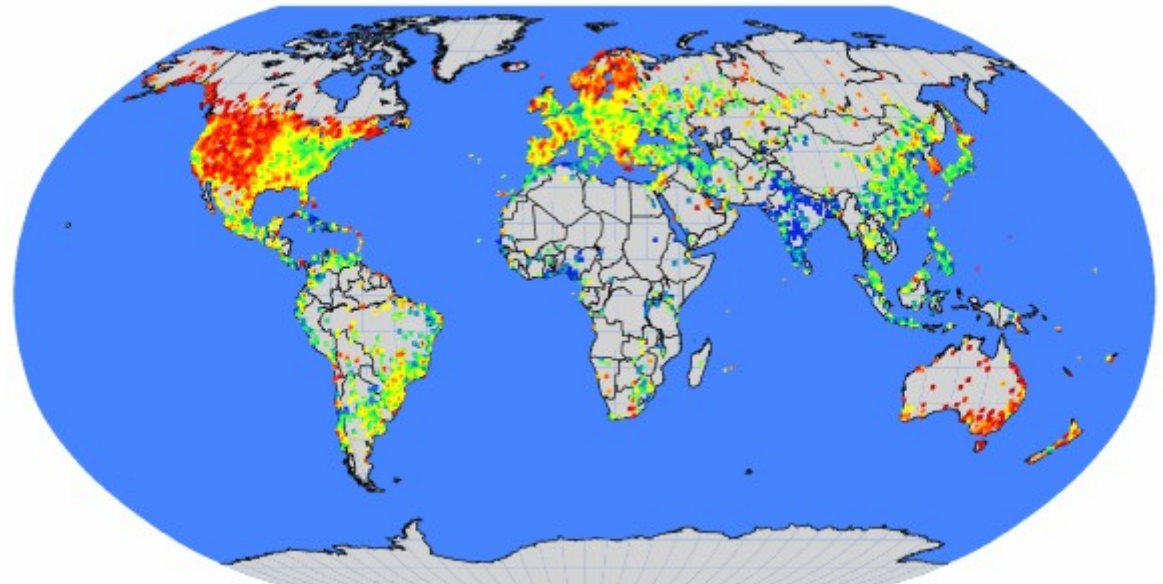
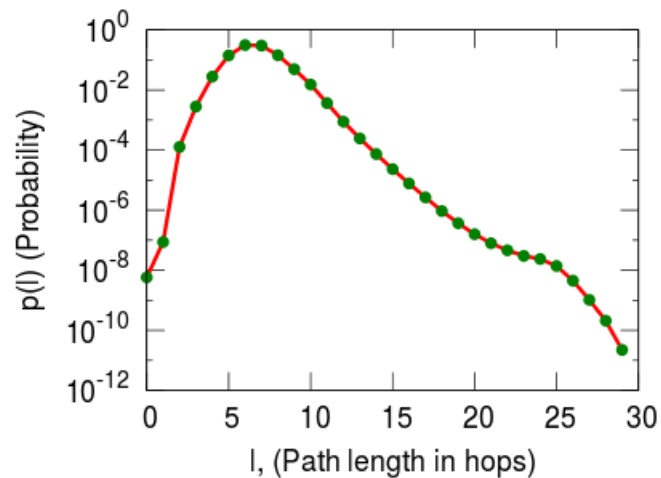





2011

# Facebook Friendships

- 69 billions of friendships between 721 millions of persons

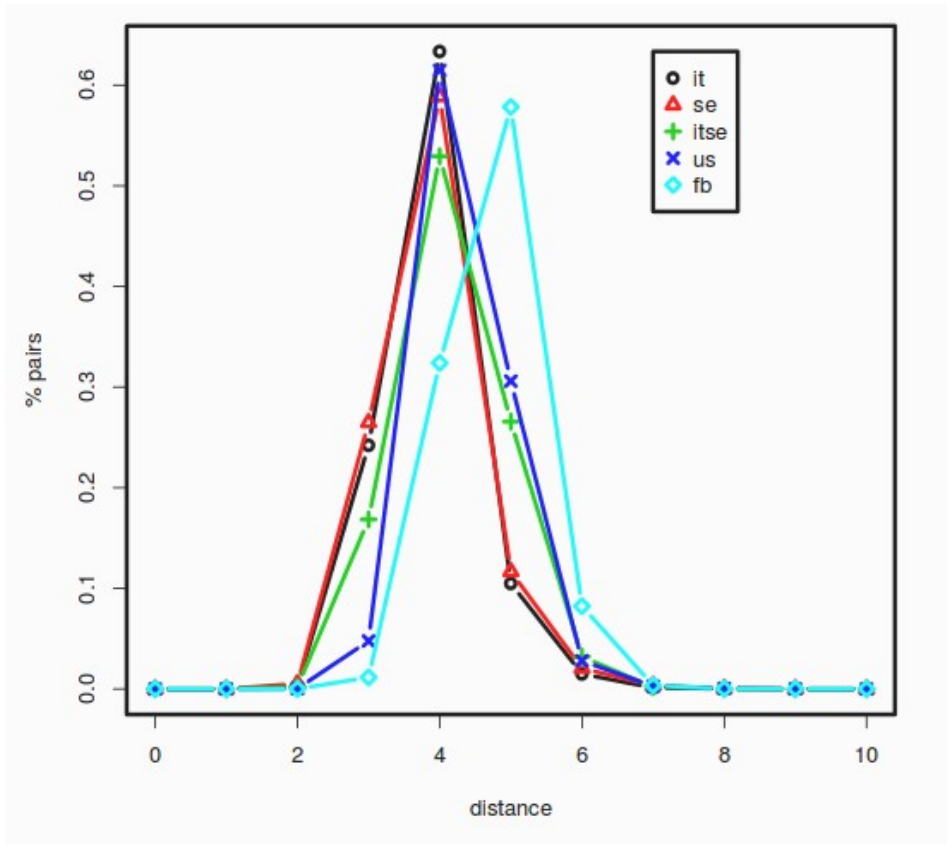

Global average: 3.74

Computer Science > Social and Information Networks

## Four Degrees of Separation

Lars Backstrom, Paolo Boldi, Marco Rosa, Johan Ugander, Sebastiano Vigna

(Submitted on 19 Nov 2011 (v1), last revised 5 Jan 2012 (this version, v3))

Figyes Karinthy, in his 1929 short story "L'ancszemek" ("Chains") suggested that any two persons are distant individuals, one of whom is a personal acquaintance, he could contact the selected individual [...]. It is not comp graph theory, but the "six degrees of separation" phrase stuck after John Guare's 1990 eponymous play. Followi one", where "distance" is the usual path length-the number of arcs in the path.) Stanley Milgram in his famous e average number of intermediaries on the path of the postcards lay between 4.4 and 5.7, depending on the sam We report the results of the first world-scale social-network graph-distance computations, using the entire Facet corresponding to 3.74 intermediaries or "degrees of separation", showing that the world is even smaller than we interesting geographic subgraphs, looking also at their evolution over time.

The networks we are able to explore are almost two orders of magnitude larger than those analysed in the previ very accurate.



2016

# Facebook Friendships

- 1.59 billions of persons

My degrees of separation



Pedro Ribeiro's average degrees of separation from everyone is 3.43.

Global average: 3.57

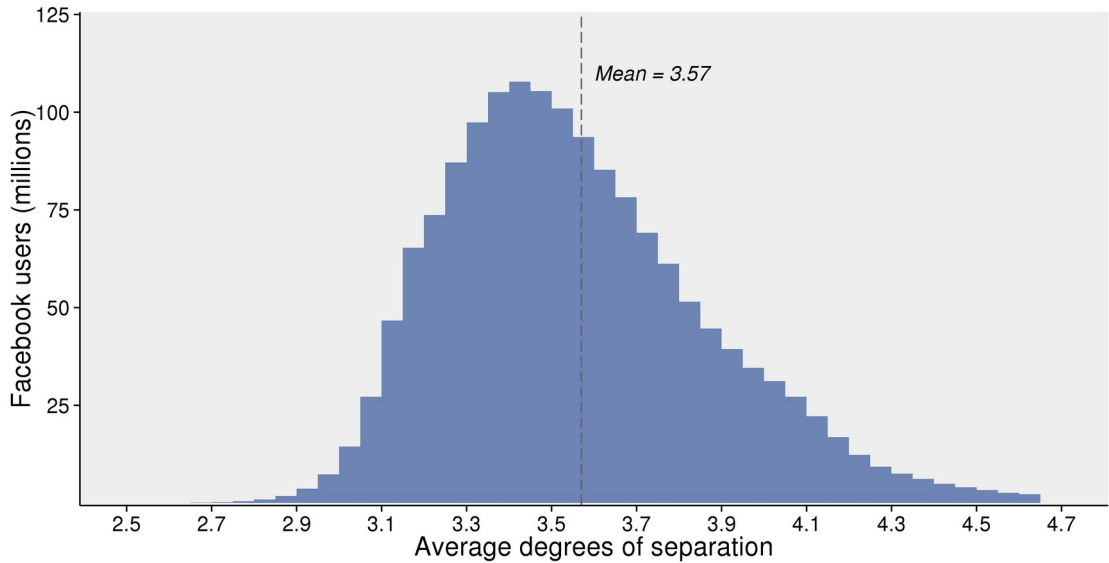

Three and a half degrees of separation

Blog

A circular network graph visualization showing connections between nodes arranged in a circle. The graph is dense with many overlapping edges, illustrating the concept of 'degrees of separation'.

Sergey Edunov, Carlos Diuk, Ismail Onur Filiz, Smriti Bhagat, Moira Burke  
4/2  
Core Data Science, Social Computing  
Gosto Partilhar 63,863



# How to explain this?

- Imagine that a person has, on average, 100 friends
  - 0 intermediates: 100
  - 1 intermediate:  $100^2 = 10.000$
  - 2 intermediates:  $100^3 = 1.000.000$
  - 3 intermediates:  $100^4 = 100.000.000$
  - 4 intermediates:  $100^5 = 10.000.000.000$
  - 5 intermediates:  $100^6 = 1.000.000.000.000$
- In practice, not all friends are new, but still there is a very fast growth

*The power of  
exponentiation*

# More examples of “Small World”

- The six degrees of Kevin Bacon
  - How many connections to link Kevin Bacon to any other actor, director, producer...
  - “Game” initiated in 1994

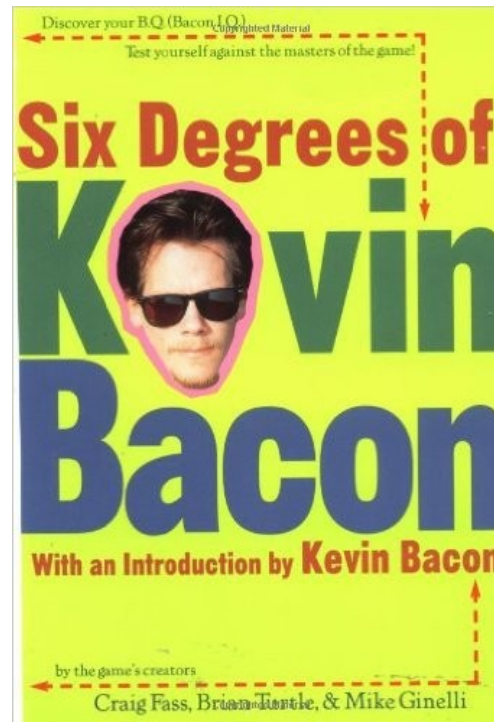





***Joaquim  
de Almeida***



*Bret Cullen*



*Joaquim de Almeida*  
(Bacon Number: 2)

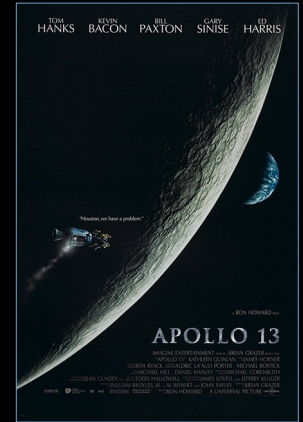

*Kevin Bacon*





**Joaquim de Almeida**  
(Bacon Number: 2)





***Nicolau  
Breyner***





**Nicolau  
Breyner**  
(Bacon Number: 3)





***Marilyn  
Monroe***



***Charlie  
Chaplin***





**Marilyn  
Monroe**

*(Bacon Number: 2)*



**Charlie  
Chaplin**

*(Bacon Number: 2)*



# More examples of “Small World”

- The six degrees of Kevin Bacon

<https://oracleofbacon.org/>

(average number: 3.009)

Kevin Bacon Number	# of persons
0	1
1	3150
2	373876
3	1340703
4	340756
5	28820
6	3383
7	451
8	52
9	8
10	1



*“People would start to come up to me in the subway and literally go...”*





*“Zero! Zero! Zero! Zero!”*

# More examples of “Small World”

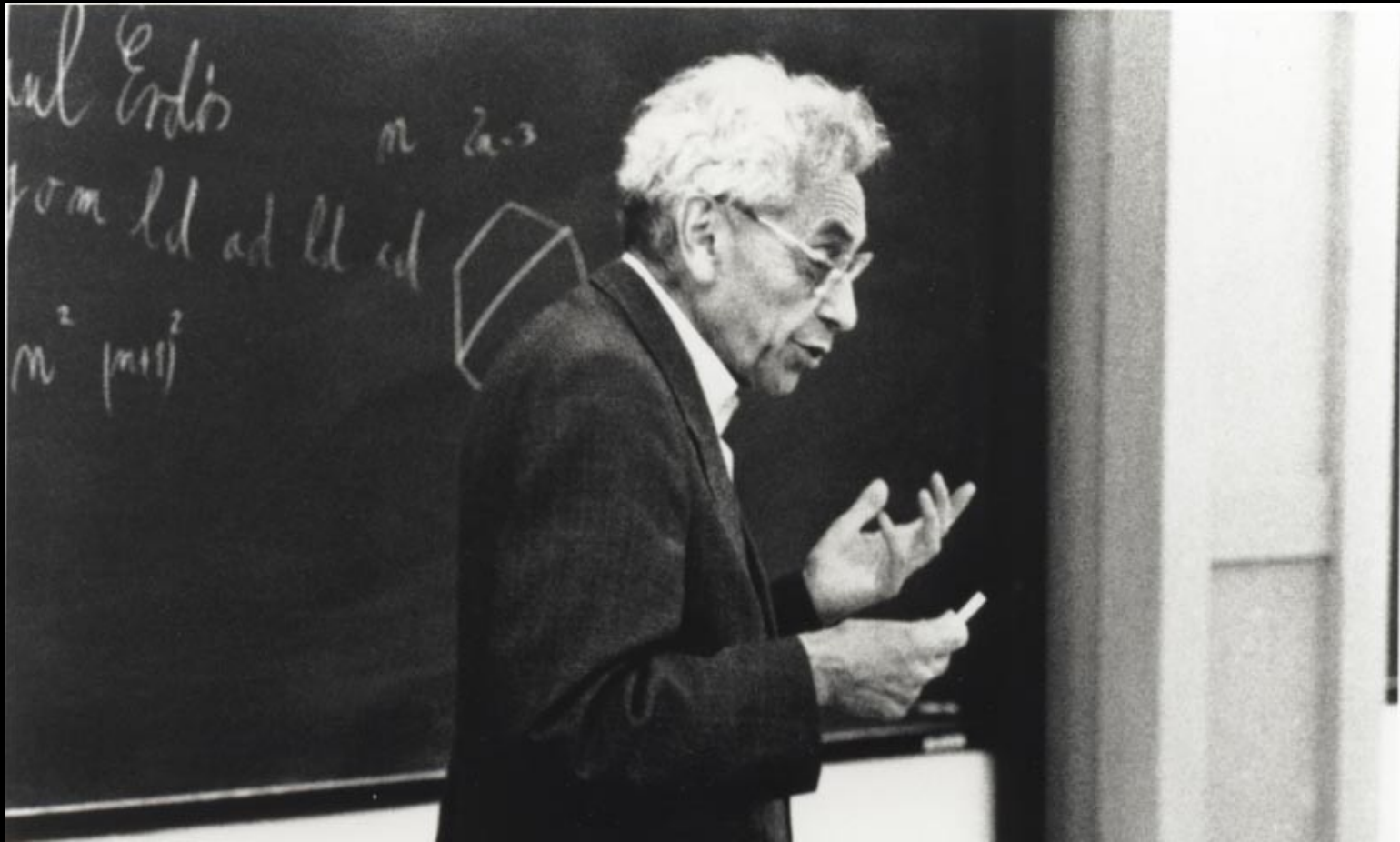

***Paul Erdős***

**Erdős Number**

# More examples of “Small World”

- Erdős number:
  - Scientific articles and very prolific mathematician

<http://wwwp.oakland.edu/enp/>



[Home](#) | [Preferences](#) | [Free Tools](#)

[Search MSC](#)

[Collaboration Distance](#)

[Current Journals](#)

[Current Publications](#)

MR Erdos Number = 4

<a href="#">Pedro Ribeiro</a>	coauthored with	<a href="#">Srinivasan Parthasarathy<sup>1</sup></a>	<a href="#">MR3385657</a>
<a href="#">Srinivasan Parthasarathy<sup>1</sup></a>	coauthored with	<a href="#">Yusu Wang</a>	<a href="#">MR3685725</a>
<a href="#">Yusu Wang</a>	coauthored with	<a href="#">Boris Aronov</a>	<a href="#">MR2347131</a>
<a href="#">Boris Aronov</a>	coauthored with	<a href="#">Paul Erdős<sup>1</sup></a>	<a href="#">MR1289067</a>

[Change First Author](#)

[Change Second Author](#)

[New Search](#)



# **Emergence of Network Science**

# Complexity

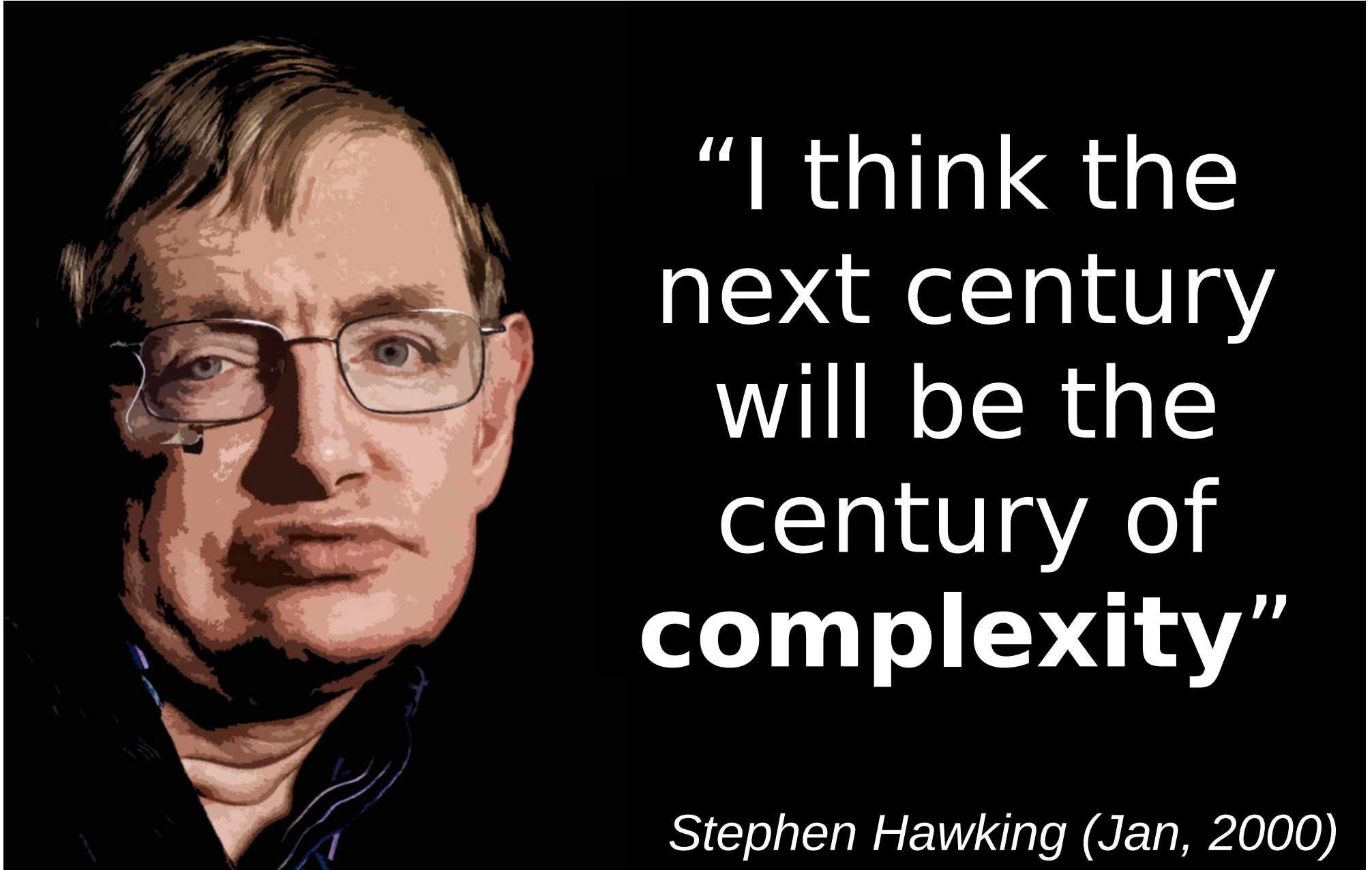

“I think the next century will be the century of **complexity**”

*Stephen Hawking (Jan, 2000)*

# The Real World is Complex

**World Population: 8 billions**





# The Real World is Complex

**World Population: 7.6 billions**

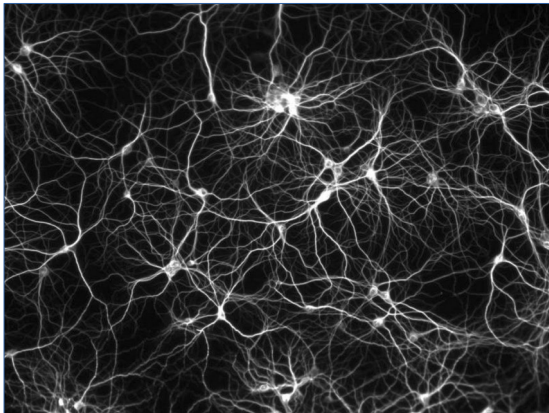

**Human Brain Neurons:  
100 billions**

# The Real World is Complex

**World Population: 7.6 billions**

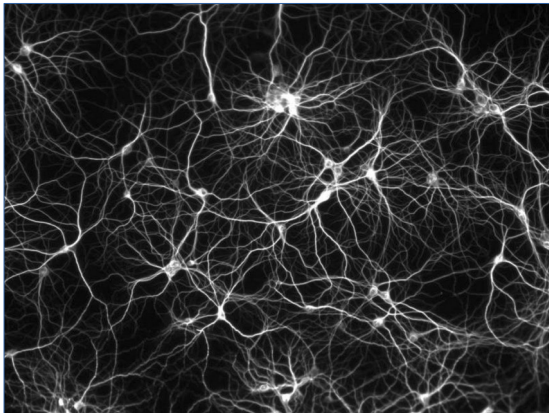

**Human Brain Neurons:  
100 billions**

**Internet Devices: >8 billions**





# Complex Systems → Complex Networks

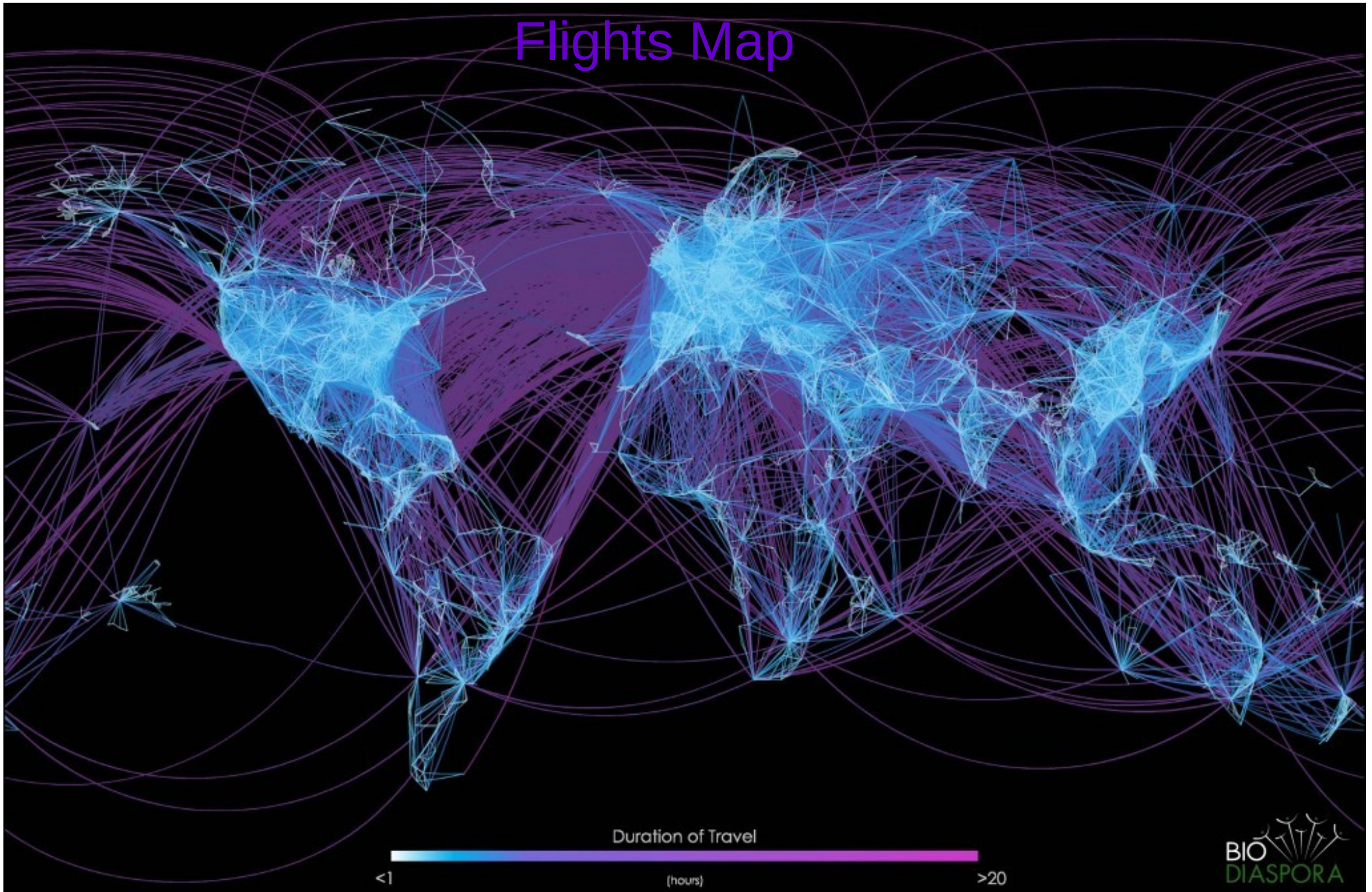



# Complex Networks are Ubiquitous

## Social

# Complex Networks are Ubiquitous

**Social**

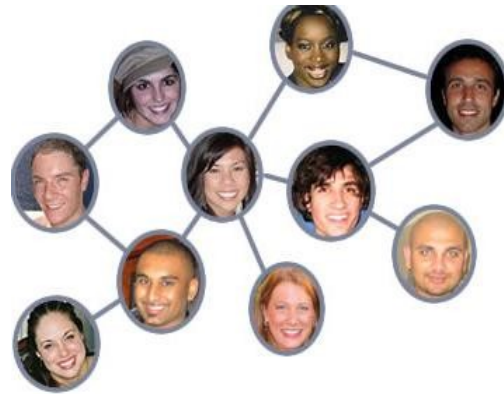

**Facebook**

# Complex Networks are Ubiquitous

## Social

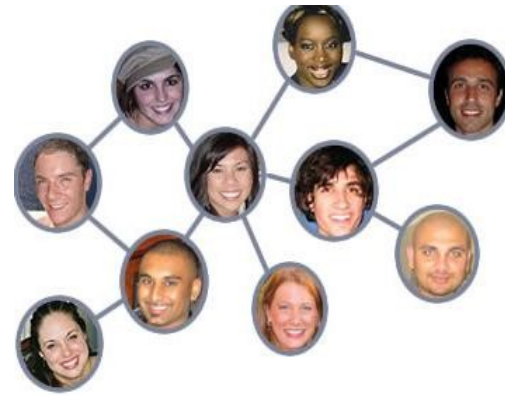

**Facebook**

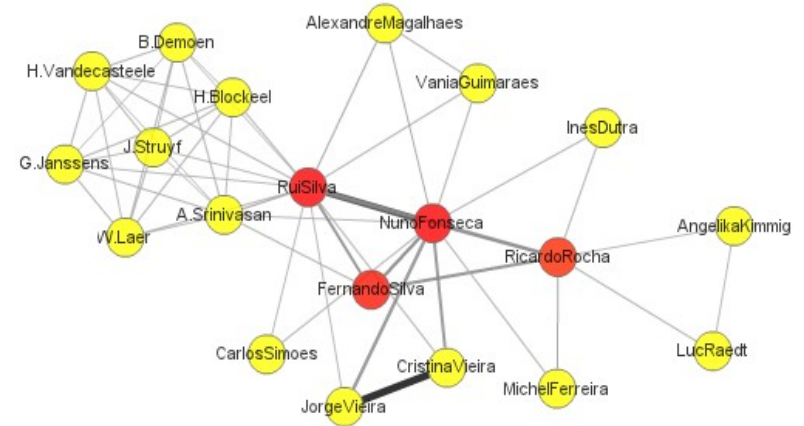

**Co-authorship**

# Complex Networks are Ubiquitous

**Social**

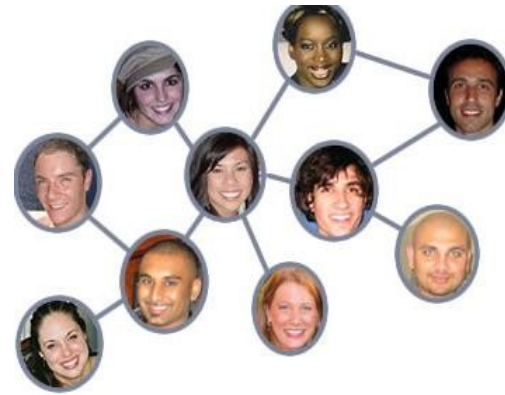

**Facebook**

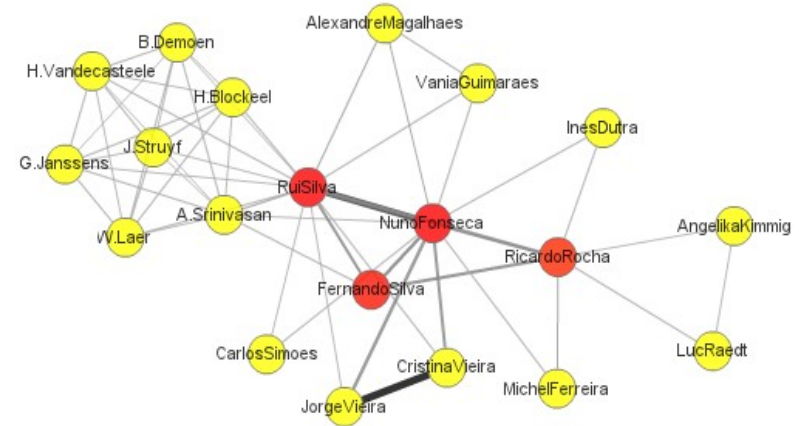

**Co-authorship**

**Biological**



# Complex Networks are Ubiquitous

## Social

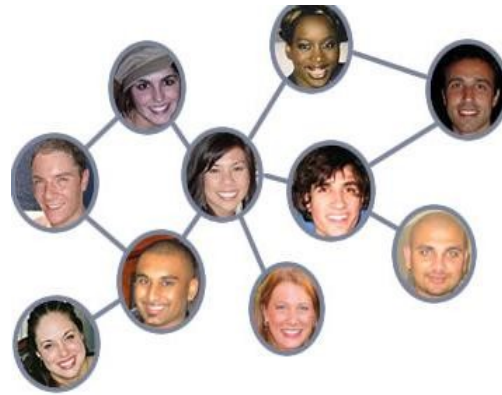

Facebook

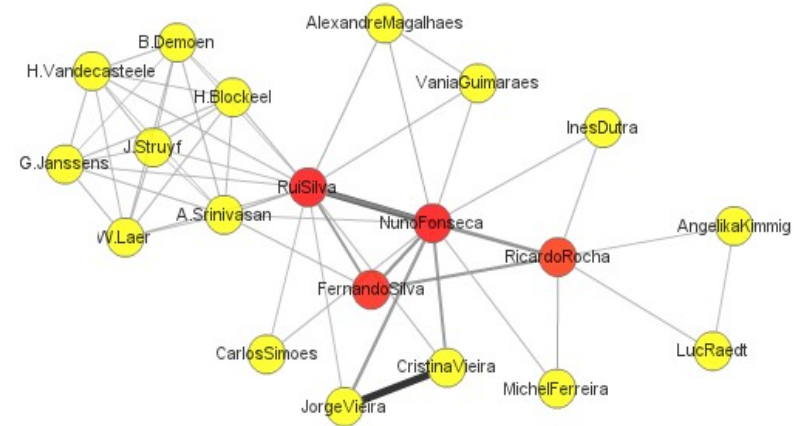

Co-authorship

## Biological

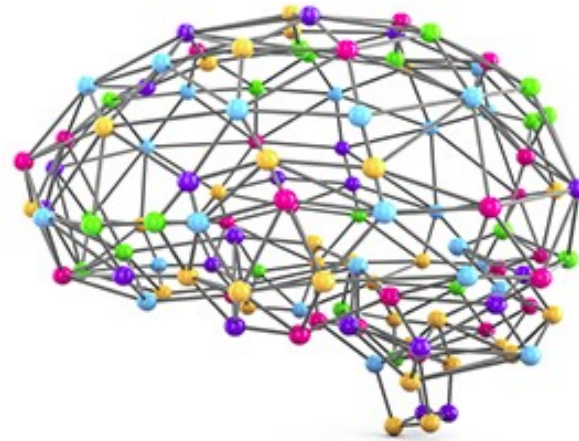

Brain

# Complex Networks are Ubiquitous

**Social**

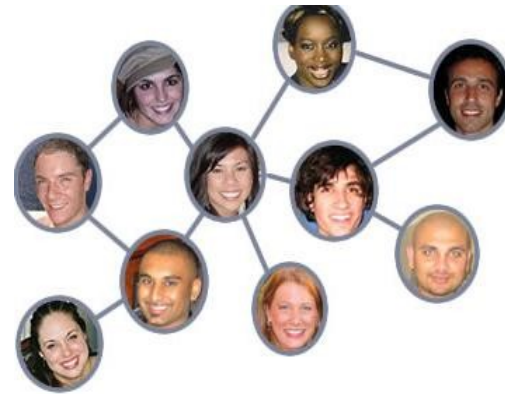

**Facebook**

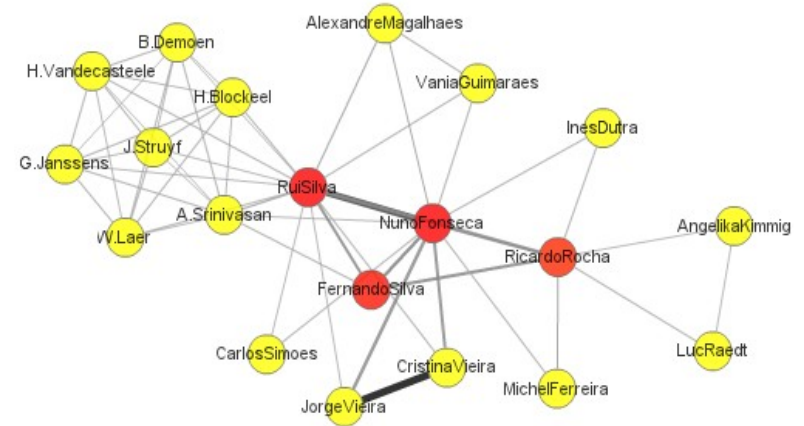

**Co-authorship**

**Biological**



**Brain**

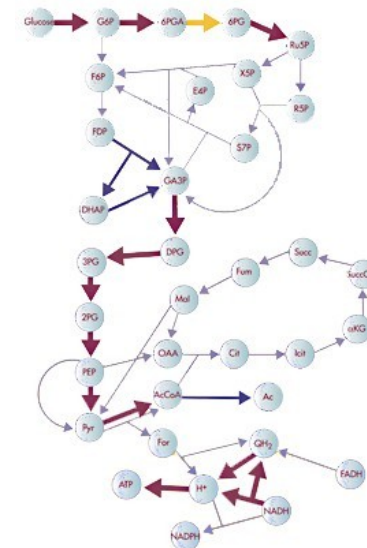

**Metabolism  
(proteins)**

# Complex Networks are Ubiquitous

## Spatial

# Complex Networks are Ubiquitous

**Spatial**

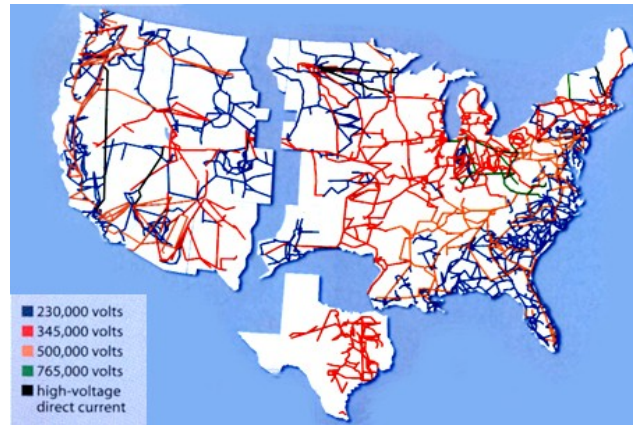

**Power**



# Complex Networks are Ubiquitous

## Spatial

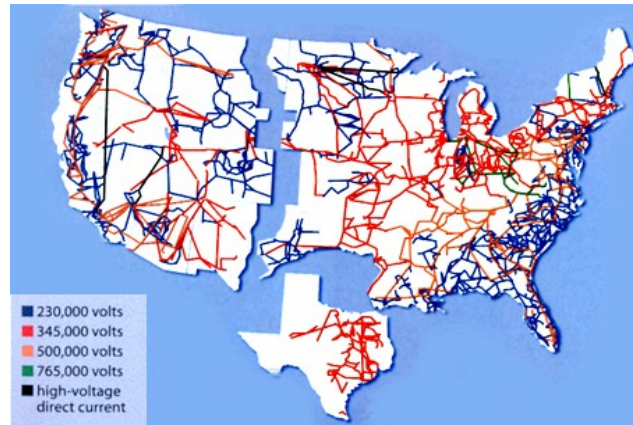

**Power**



**Roads**

# Complex Networks are Ubiquitous

**Spatial**

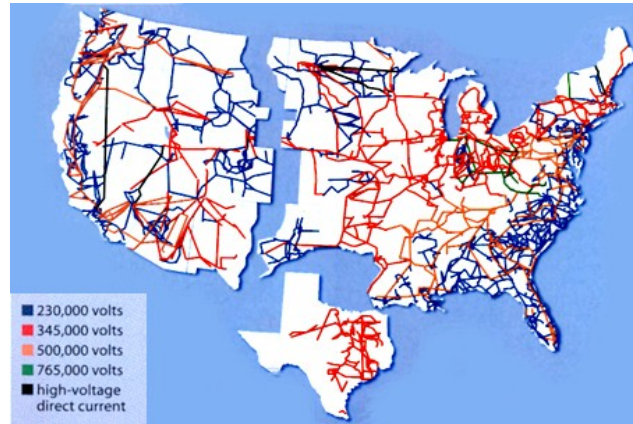

**Power**



**Roads**

**Software**

# Complex Networks are Ubiquitous

**Spatial**

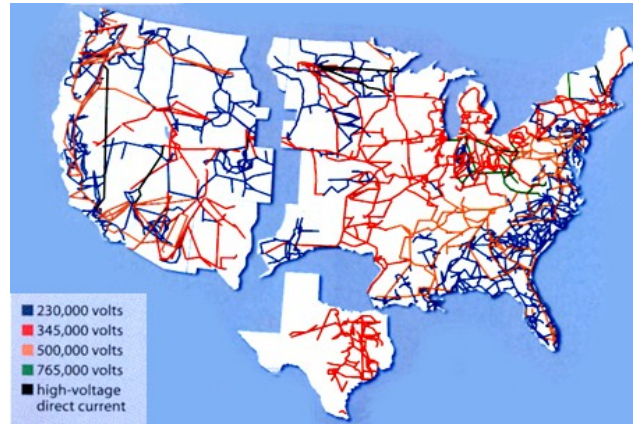

**Power**



**Roads**

**Software**

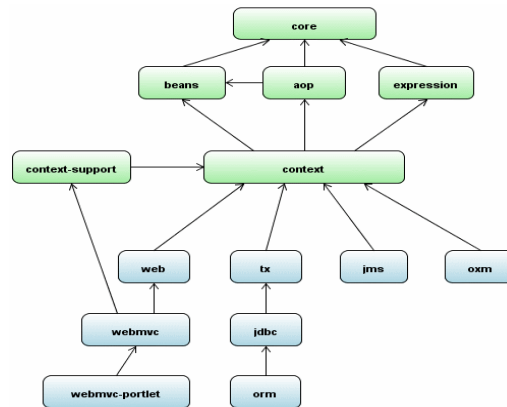

**Module  
Dependency**

# Complex Networks are Ubiquitous

**Spatial**

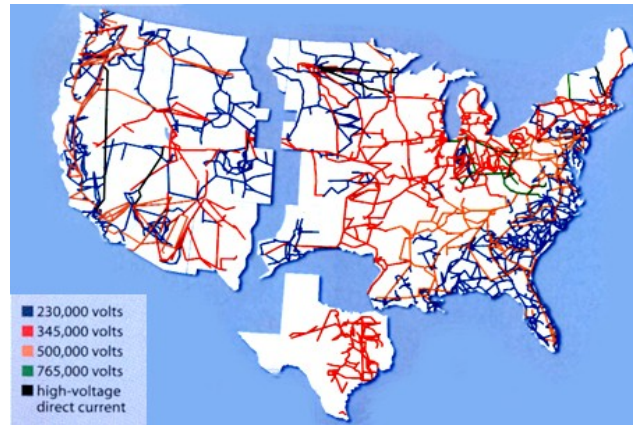

**Power**



**Roads**

**Software**

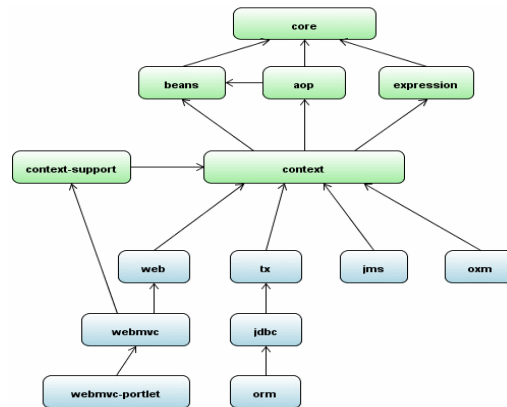

**Module  
Dependency**

**Text**



# Complex Networks are Ubiquitous

**Spatial**

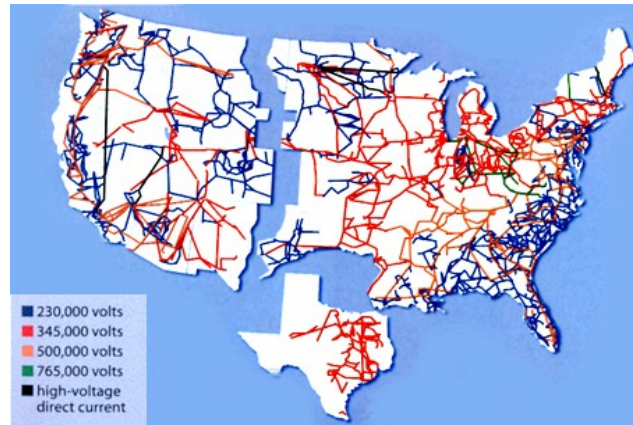

**Power**



**Roads**

**Software**

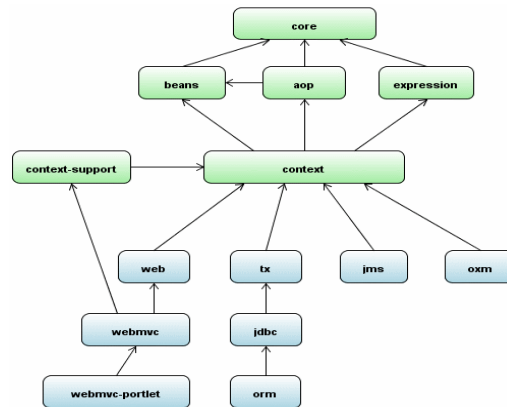

**Module  
Dependency**

**Text**

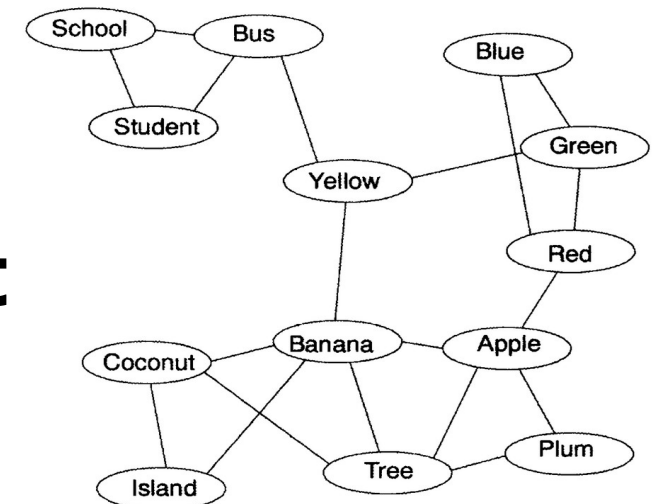

**Semantic**

# Complex Networks are Ubiquitous

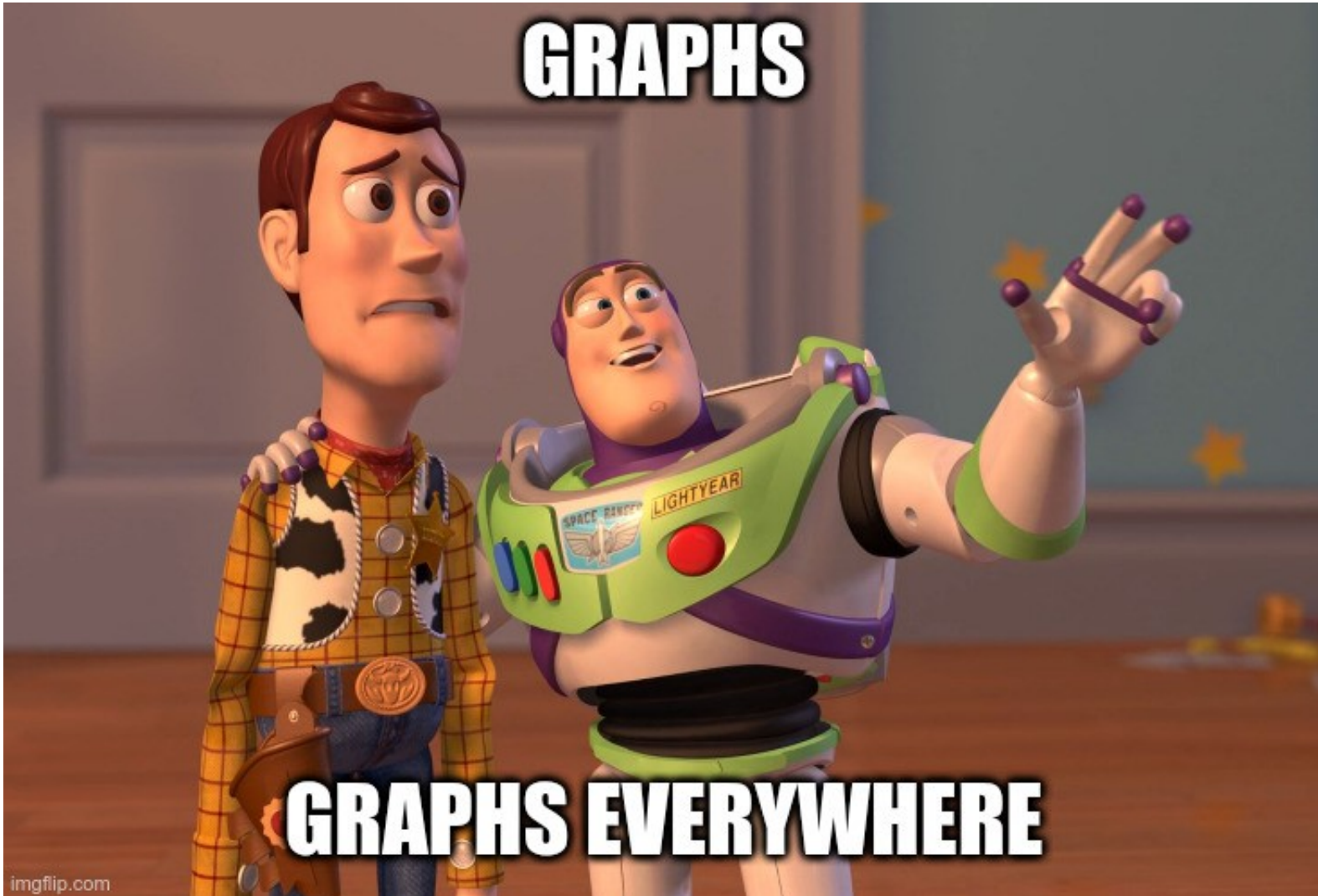

# Network Science

Behind many complex systems there is a **network** that defines the **interactions** between the components

In order to understand the systems...  
we need to understand the **networks!**

# Network Science

- **Network Science** has been emerging on this century as a new discipline:
  - Origins on **graph theory** and **social** network research

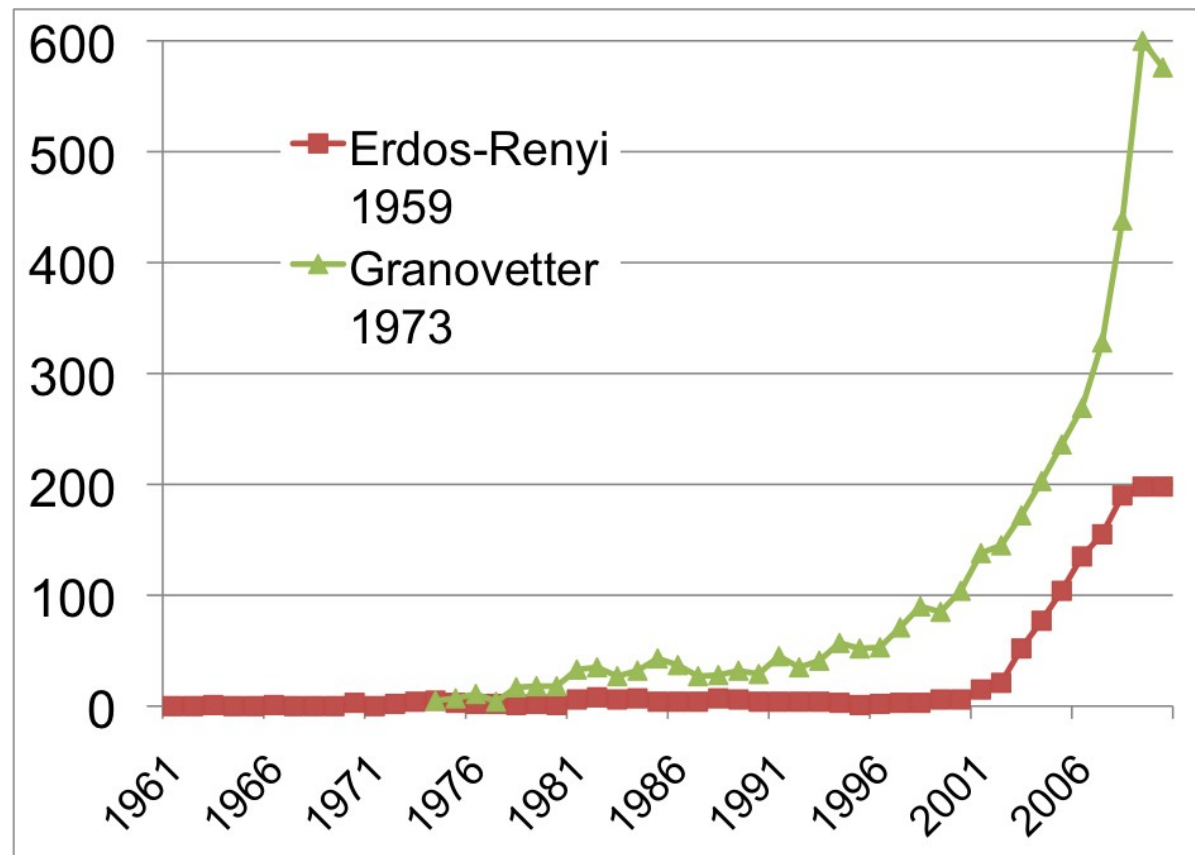

Image: Adapted from (Barabasi, 2015)



# Why now?

- Two main contributing factors:

# Why now?

- Two main contributing factors:

**1) The emergence of network maps**

# Why now?

- Two main contributing factors:

## 1) The emergence of **network maps**

- Movie actor network: 1998
- World Wide Web: 1999
- Citation Network: 1998
- Metabolic Network: 2000
- PPI Network: 2001

# Why now?

- Two main contributing factors:

## 1) The emergence of **network maps**

- Movie actor network: 1998
- World Wide Web: 1999
- Citation Network: 1998
- Metabolic Network: 2000
- PPI Network: 2001
- **436 nodes** – 2003  
(email exchange, Adamic-Adar, SocNets)
- **43,553 nodes** – 2006  
(email exchange, Kossinets-Watts, Science)
- **4.4 million nodes** – 2005  
(friendships, Liben-Nowell, PNAS)
- **800 million nodes** – 2011  
(Facebook, Backstrom et al.)

**Size matters!**



# Why now?

- Two main contributing factors:

**2) Universality of network characteristics**

# Why now?

- Two main contributing factors:

## 2) Universality of network **characteristics**

- The architecture and topology of networks from different domains exhibit more similarities than what one would expect

# Why now?

- Two main contributing factors:

## 2) Universality of network characteristics

- The architecture and topology of networks from different domains exhibit more similarities than what one would

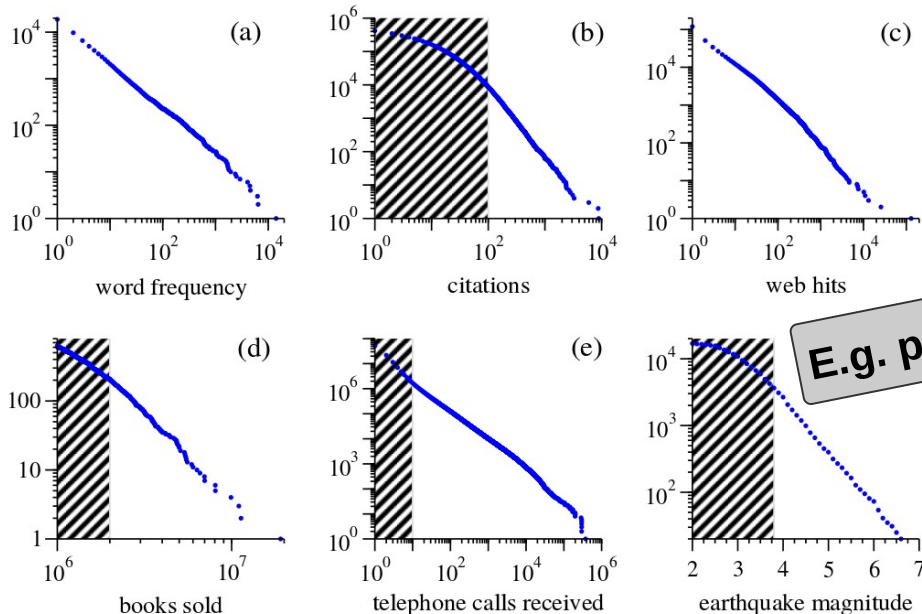

E.g. power laws

Many real world networks are power law

	exponent $\alpha$ (in/out degree)
film actors	2.3
telephone call graph	2.1
email networks	1.5/2.0
sexual contacts	3.2
WWW	2.3/2.7
internet	2.5
peer-to-peer	2.1
metabolic network	2.2
protein interactions	2.4

Image: Adapted from (Newman, 2005)

Image: Adapted from Leskovec, 2015

# Impact of Network Science: Economic



Google

facebook

CISCO



# Impact of Network Science: Scientific

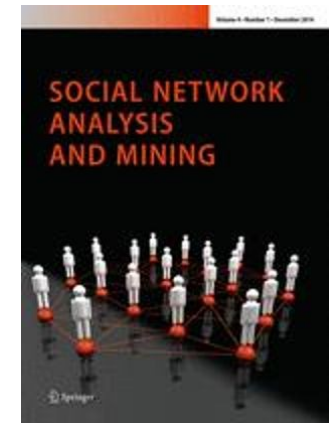
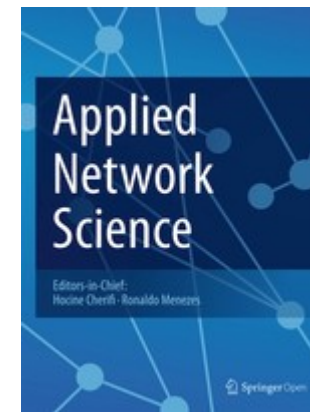
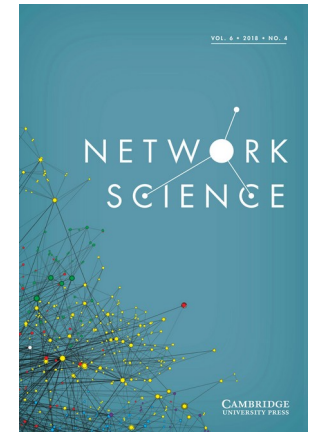
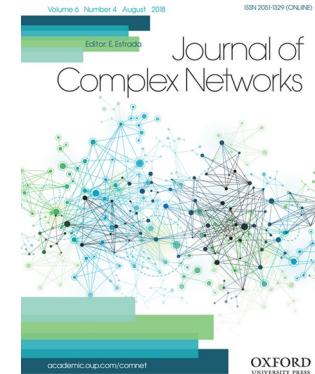
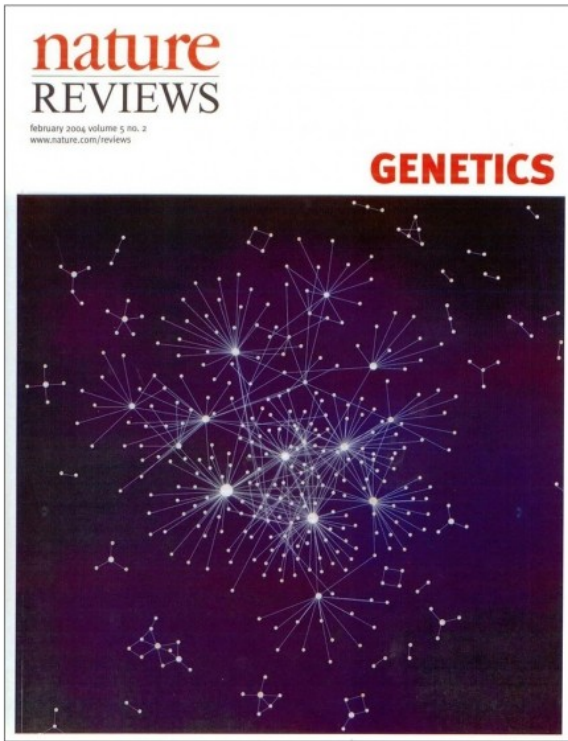

**Northeastern University**  
*Network Science Institute*

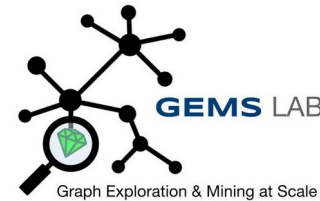

# Impact of Network Science: Societal

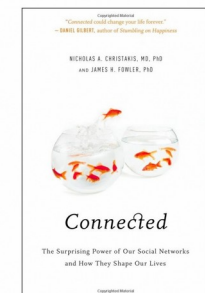
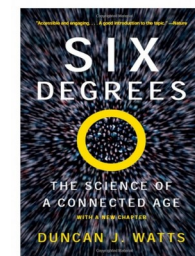
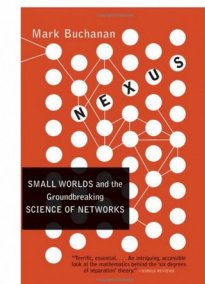
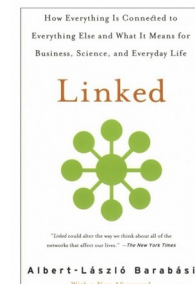
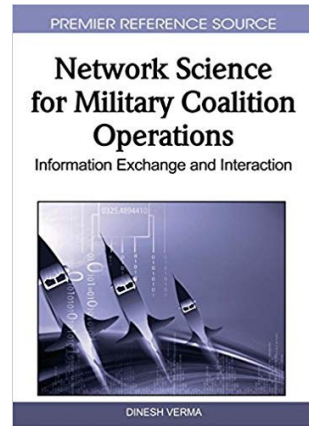

# Reasoning about Networks

- **What do we hope to achieve from studying networks?**
  - Patterns and statistical **properties** of network data
  - **Design principles** and **models**
  - **Algorithms** and **predictive** models to answer questions and make predictions

# Mining and Learning with Graphs

- **How do we mine networks?**
  - **Empirically:** Study network data to find organizational principles
    - How do we measure and quantify networks?
  - **Mathematical models:** Graph theory and statistical models
    - Models allow us to understand behaviors and distinguish surprising from expected phenomena
  - **Algorithms** for analyzing graphs
    - Hard computational challenges

# Network Science Topics

- Some possible tasks:



# Network Science Topics

- Some possible tasks:
  - General Patterns
    - Ex: “scale-free”, “small-world”

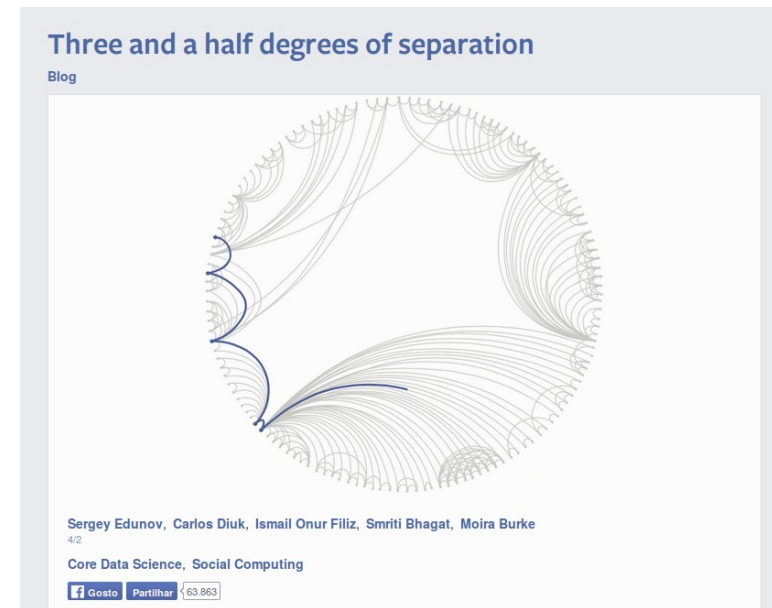
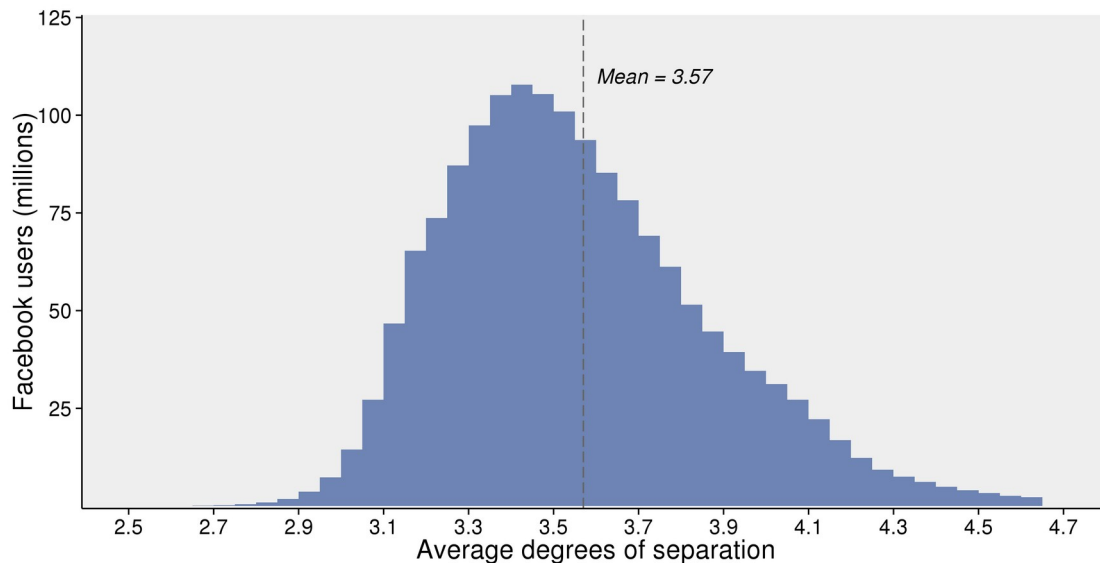

# Network Science Topics

- Some possible tasks:
  - General Patterns
    - Ex: “scale-free”, “small-world”
  - Community Detection
    - What groups of nodes are “related”?

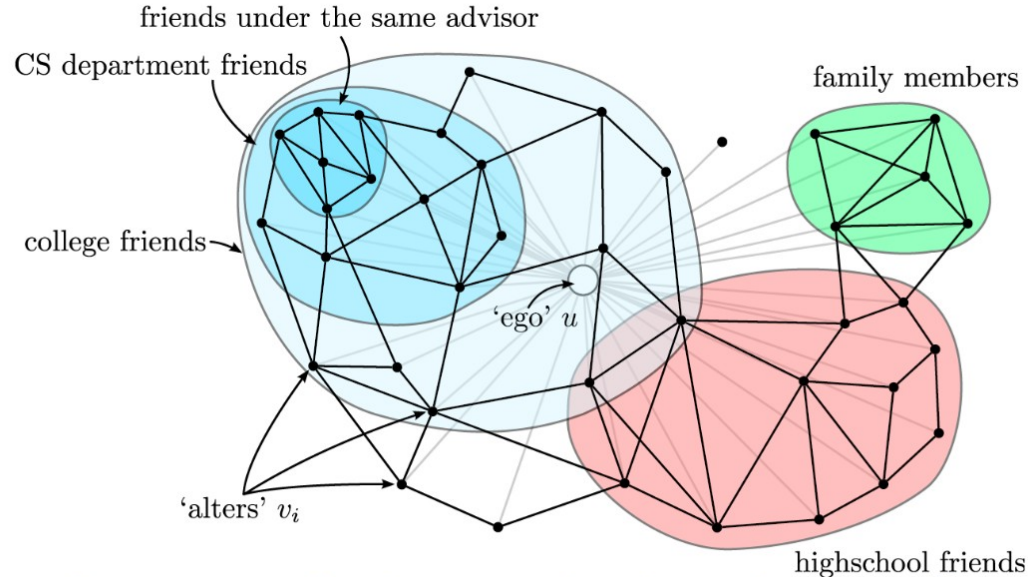

**Discover circles and why they exist**

# Network Science Topics

- Some possible tasks:
  - General Patterns
    - Ex: “scale-free”, “small-world”
  - Community Detection
    - What groups of nodes are “related”?
  - Node Classification
    - Importance and function of a certain node?

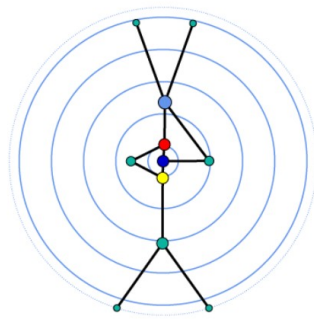
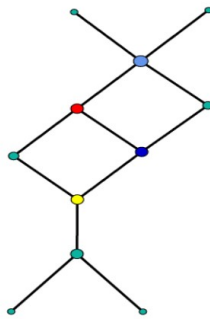

Closeness

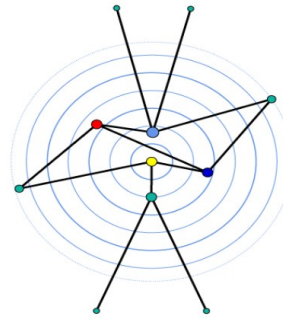

Betweenness

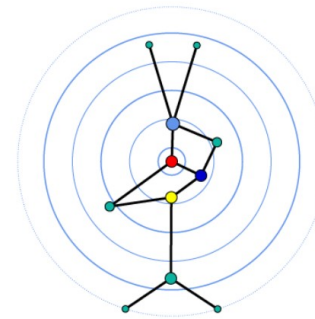

Eigenvector

# Network Science Topics

- Some possible tasks:
  - General Patterns
    - Ex: “scale-free”, “small-world”
  - Community Detection
    - What groups of nodes are “related”?
  - Node Classification
    - Importance and function of a certain node?
  - Network Comparison
    - What is the type of the network?

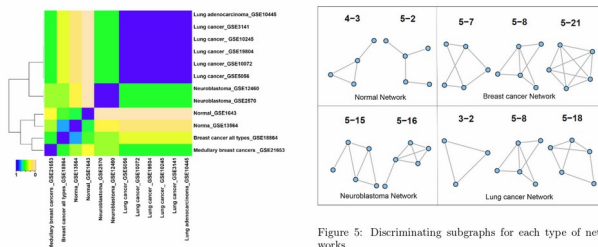
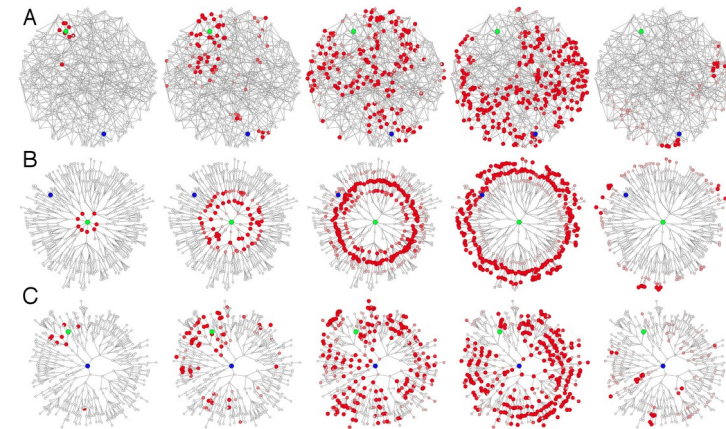

Figure 5: Discriminating subgraphs for each type of networks.

# Network Science Topics

- Some possible tasks:
  - General Patterns
    - Ex: “scale-free”, “small-world”
  - Community Detection
    - What groups of nodes are “related”?
  - Node Classification
    - Importance and function of a certain node?
  - Network Comparison
    - What is the type of the network?
  - Information Propagation
    - Epidemics? Robustness?





# Network Science Topics

- Some possible tasks:
  - General Patterns
    - Ex: “scale-free”, “small-world”
  - Community Detection
    - What groups of nodes are “related”?
  - Node Classification
    - Importance and function of a node
  - Network Comparison
    - What is the type of the network?
  - Information Propagation
    - Epidemics? Robustness?
  - Link prediction
    - Future connections? Errors in graph constructions?

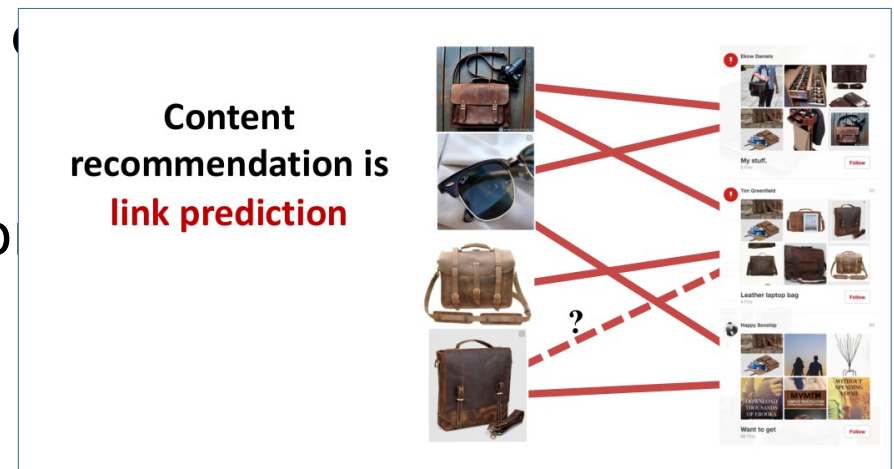

# **Brief Introduction to Graph Theory and Network Vocabulary**

# Terminology

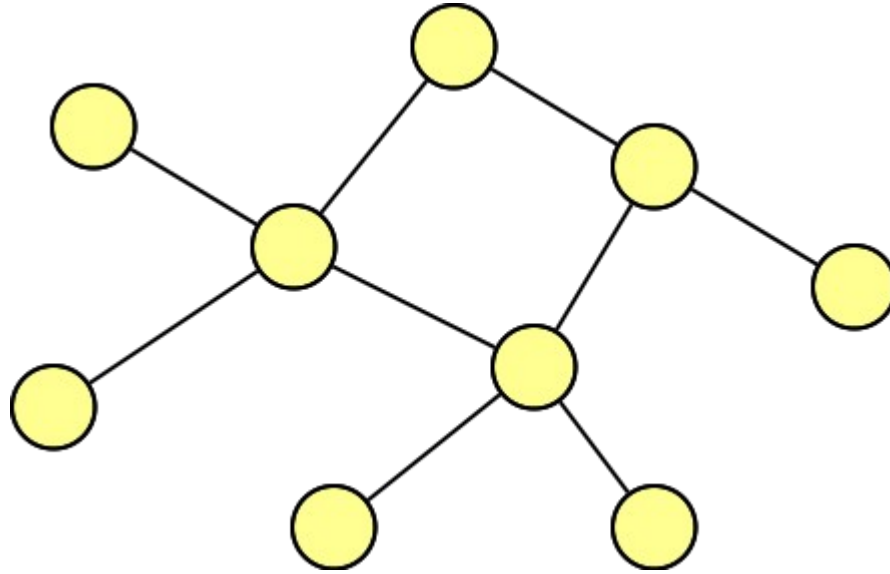

- **Objects:** nodes, vertices  $V$
- **Interactions:** links, edges  $E$
- **System:** network, graph  $G(V,E)$

# Networks or Graphs?

- **Network** often refers to real systems
  - Web, Social network, Metabolic network
  - Language: Network, node, link
- **Graph** is a mathematical representation of a network
  - Web graph, Social graph (a Facebook term)
  - Language: Graph, vertex, edge

We will try to make this distinction whenever it is appropriate, but **in most cases we will use the two terms interchangeably**

# Choosing the Network

- If you connect individuals that work with each other, you will explore a **professional network**
- If you connect those that are friends, you will be exploring a **friendship network**
- If you connect scientific papers that cite each other, you will be studying the **citation network**
  
- **Another example:** if you connect all papers with the same word in the title, what will you be exploring?
- There might be **several possible representations**

The choice of the network representation of a given domain determines our ability to use it successfully



# Simple and multi-graphs

- **In general, graphs may have self-loops and multi-edges**
  - A graph with either is called a **multi-graph**

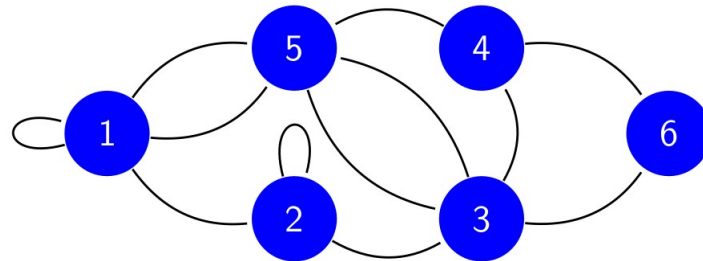

- We will mostly work with **simple graphs**, with no self-loops or multi-edges

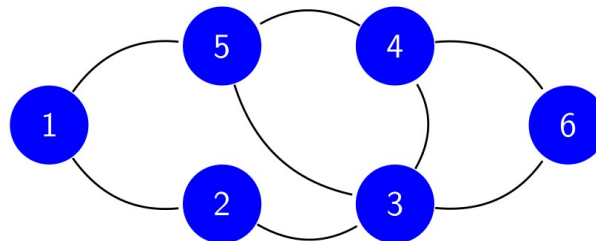

# Network Types

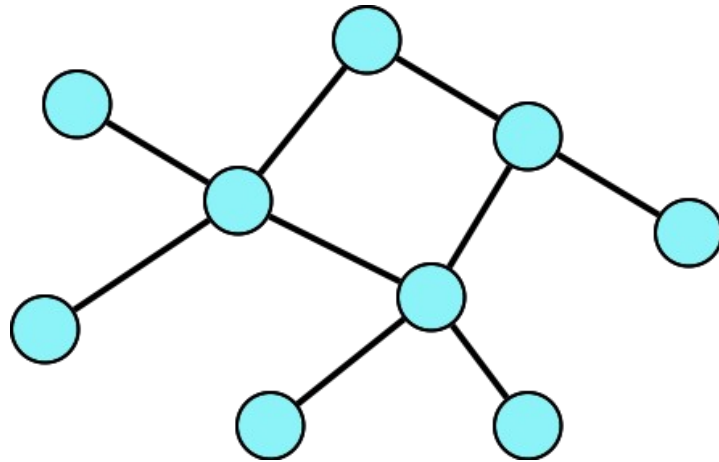

Undirected

- co-authorship networks
- actor networks
- facebook friendships

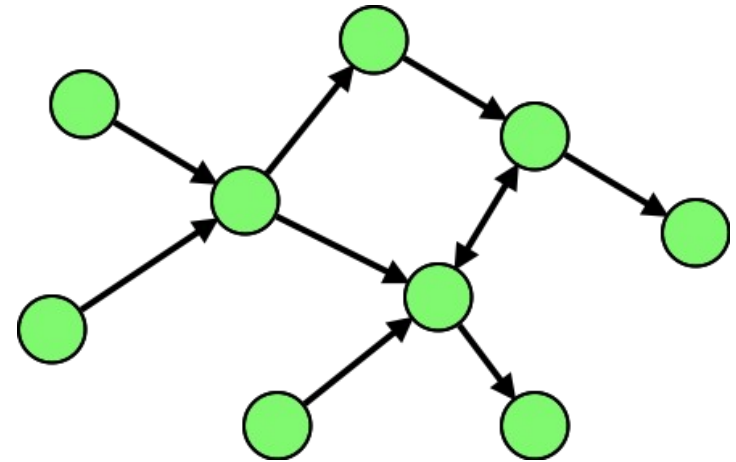

Directed

- www hyperlinks
- phone calls
- roads network

# Network Types

## Edge Attributes

- Examples:
  - **Weight** (duration call, distance road, ...)
  - **Ranking** (best friend, second best friend, ...)
  - **Type** (friend, relative, co-worker, ...) [colored edges]
  - We can have a set of **multiple** attributes

## Node Attributes

- Examples:
  - **Type** (nationality, sex, age, ...) [colored nodes]
  - We can have a set of **multiple** attributes

# Network Types

## Multiplex Networks

- Different layers (types) of connections

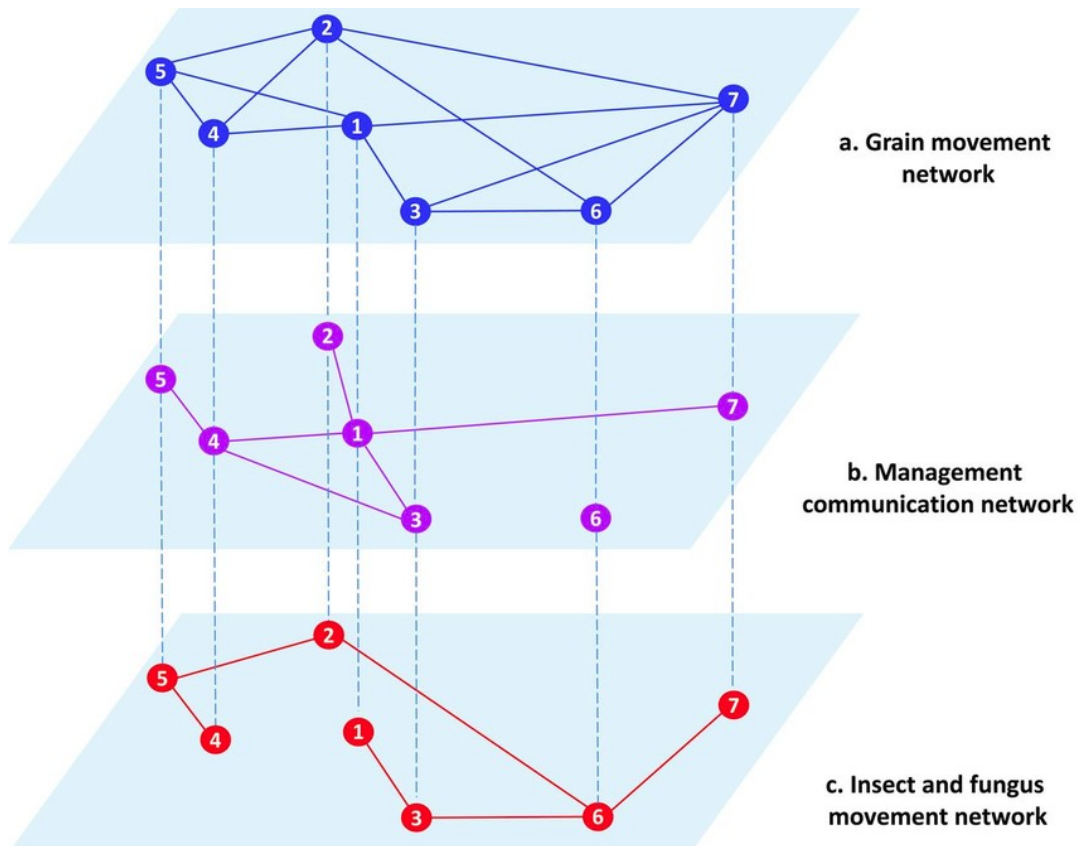

# Network Types

## Temporal Networks

- Evolution over time

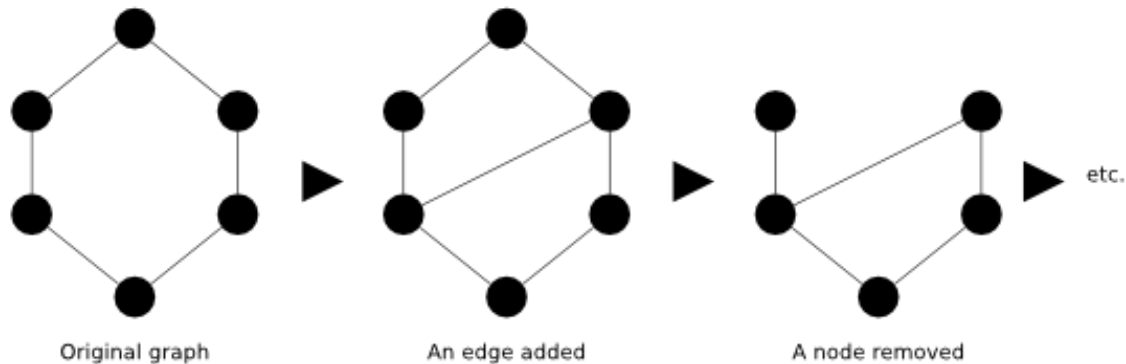



# Node Properties

- **From immediate connections**

- **Outdegree**

how many directed edges originate at node

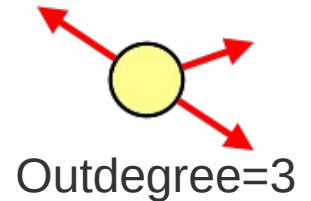

- **Indegree**

how many directed edges are incident on a node

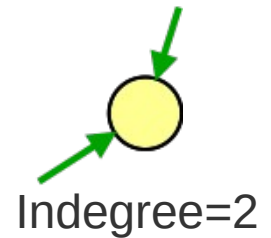

- **Degree (in or out)**

number of outgoing and incoming edges

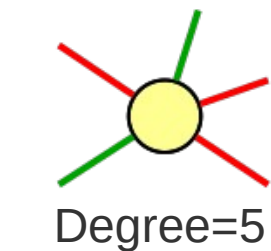

# Node Properties

- **Degree related metrics:**

- **Degree sequence**

an ordered list of the (in,out) degree of each node

- In-degree sequence: [4, 2, 1, 1, 0]
- Out-degree sequence: [3, 2, 2, 1, 0]
- Degree sequence: [4, 3, 3, 3, 3]

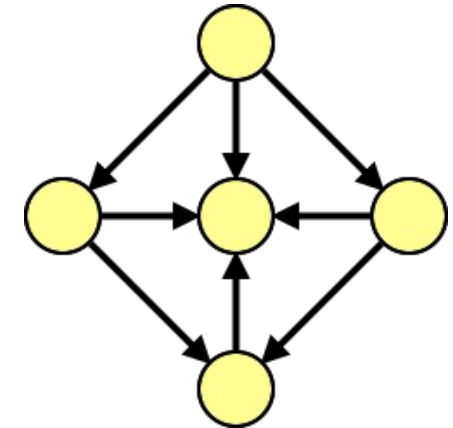

- **Degree Distribution**

a frequency count of the occurrences of each degree  
[usually plotted as probability → normalization]

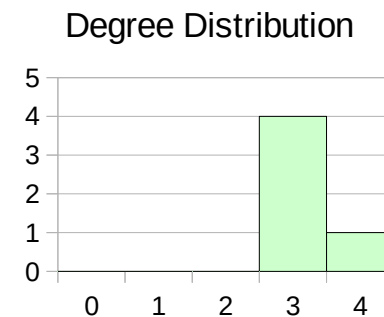
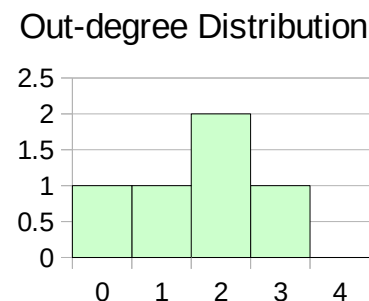
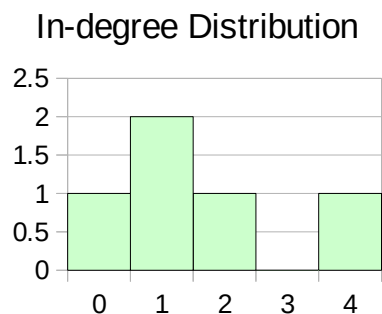

# Sparsity of Networks

- **Real Networks are usually very Sparse!**

Network	Dir/Undir	Nodes	Edges	Avg. Degree
Internet	Undirected	192,244	609,066	<b>6.33</b>
WWW	Directed	325,729	1,479,134	<b>4.60</b>
Power Grid	Undirected	4,941	6,594	<b>2.67</b>
Mobile Phone Calls	Directed	36,595	91,826	<b>2.51</b>
Email	Directed	57,194	103,731	<b>1.81</b>
Science Collaboration	Undirected	23,133	93,439	<b>8.08</b>
Actor Network	Undirected	702,388	29,397,908	<b>83.71</b>
Citation Network	Directed	449,673	4,689,479	<b>10.43</b>
E. Coli Metabolism	Directed	1,039	5,082	<b>5.58</b>
Protein Interactions	Undirected	2,018	2,930	<b>2.90</b>

- A graph where every pair of nodes is connected is called a **complete graph** (or a **clique**)

*Table: Adapted from (Barabasi, 2015)*

# Connectivity

- **Not everything is connected**

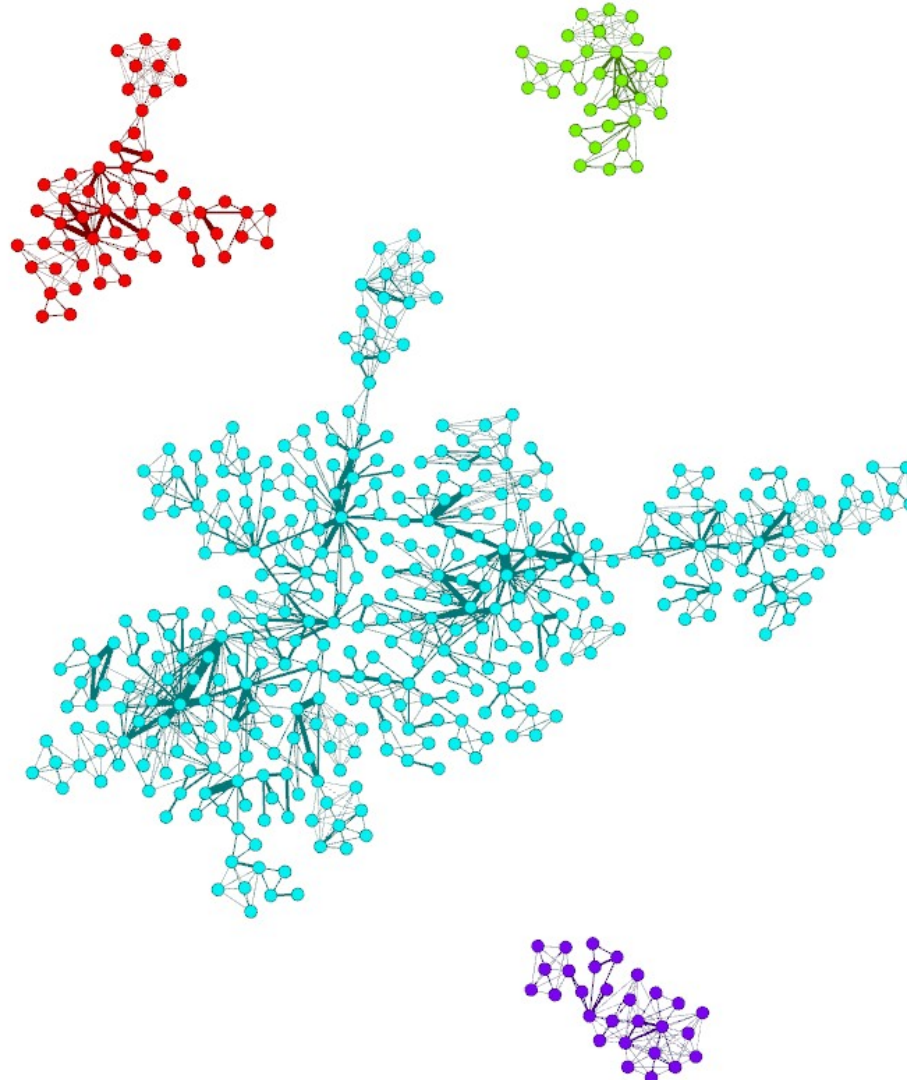

# Connectivity

- If the largest component has a large fraction of the nodes we call it the **giant component**

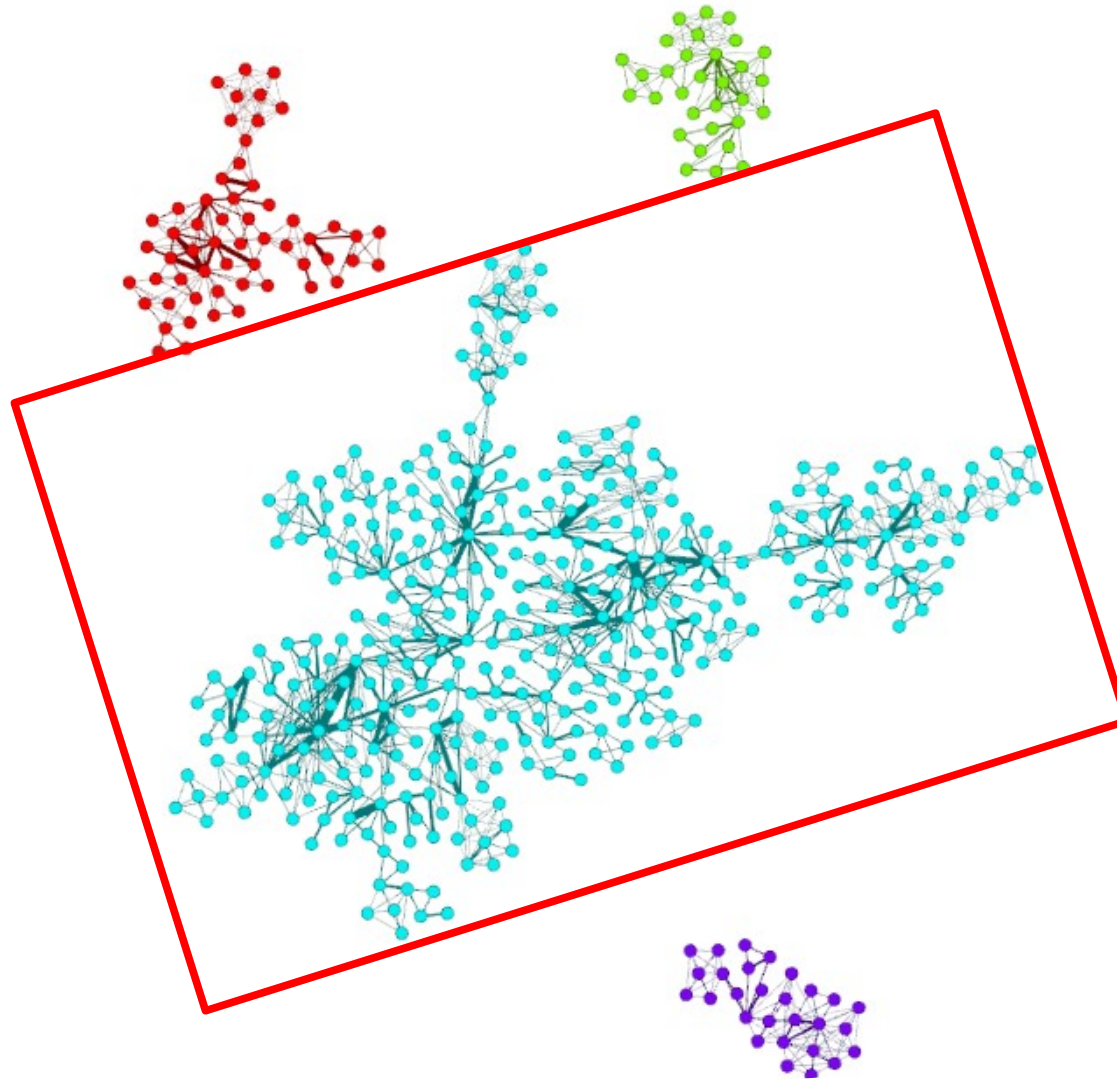

# Bipartite

- A **bipartite graph** is a graph whose nodes can be divided into two disjoint sets **U** and **V** such that every edge connects a node in **U** to one in **V**.

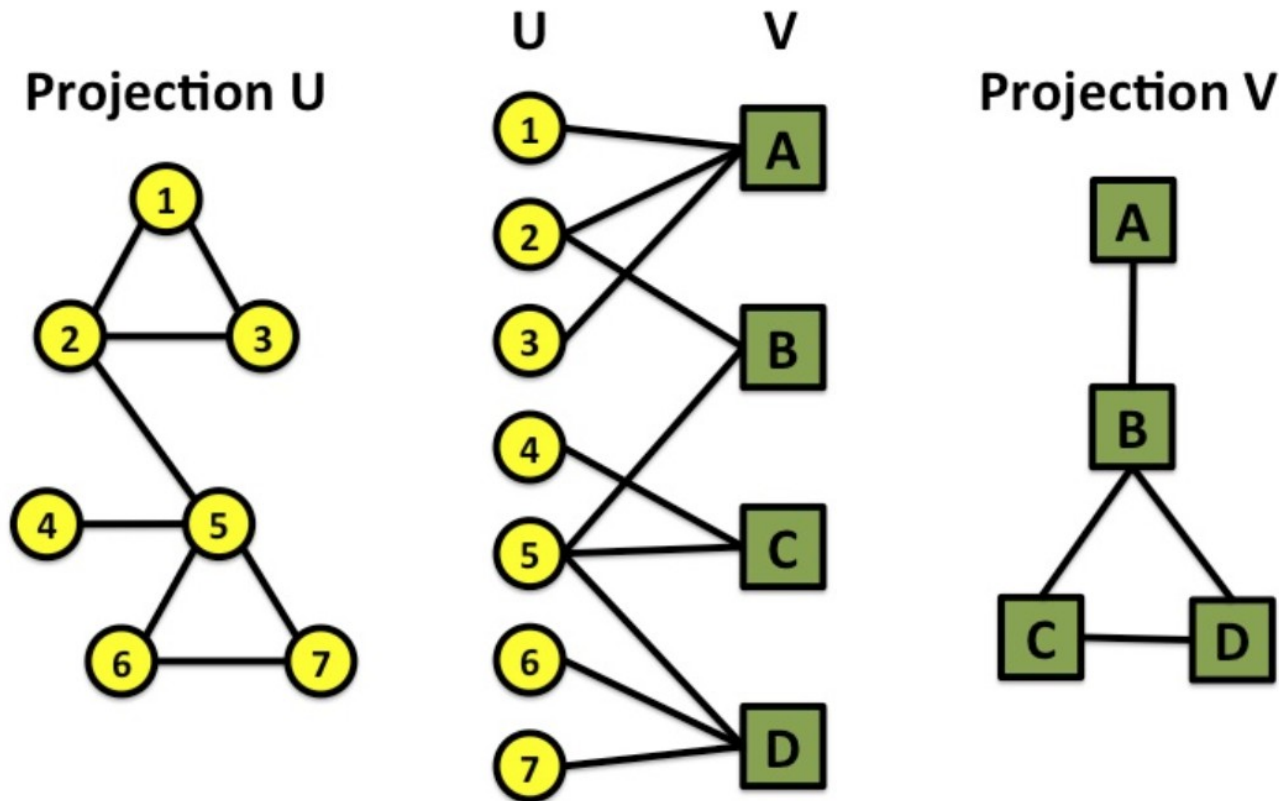

## Example:

- Actor Network
  - . U = Actor
  - . V = Movies

Image: Adapted from Leskovec, 2015



# Bipartite Network Projections

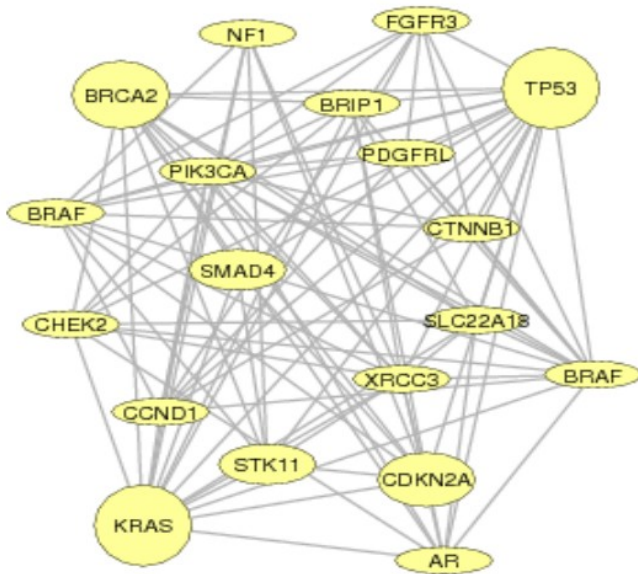

**Gene network**

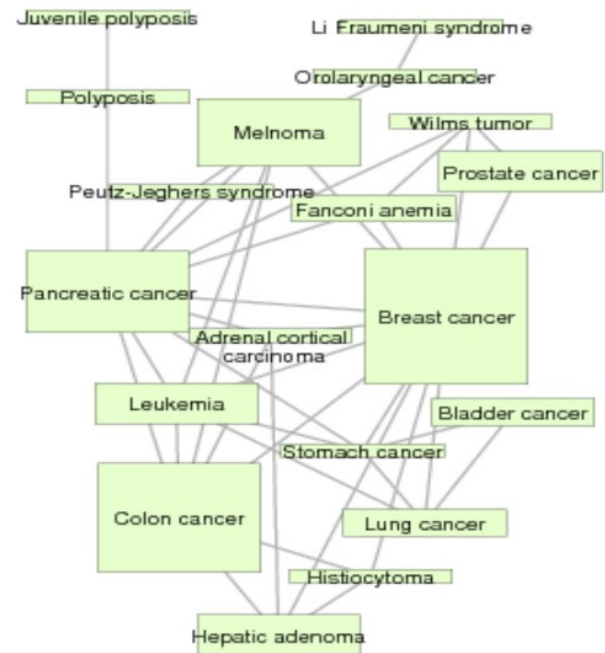
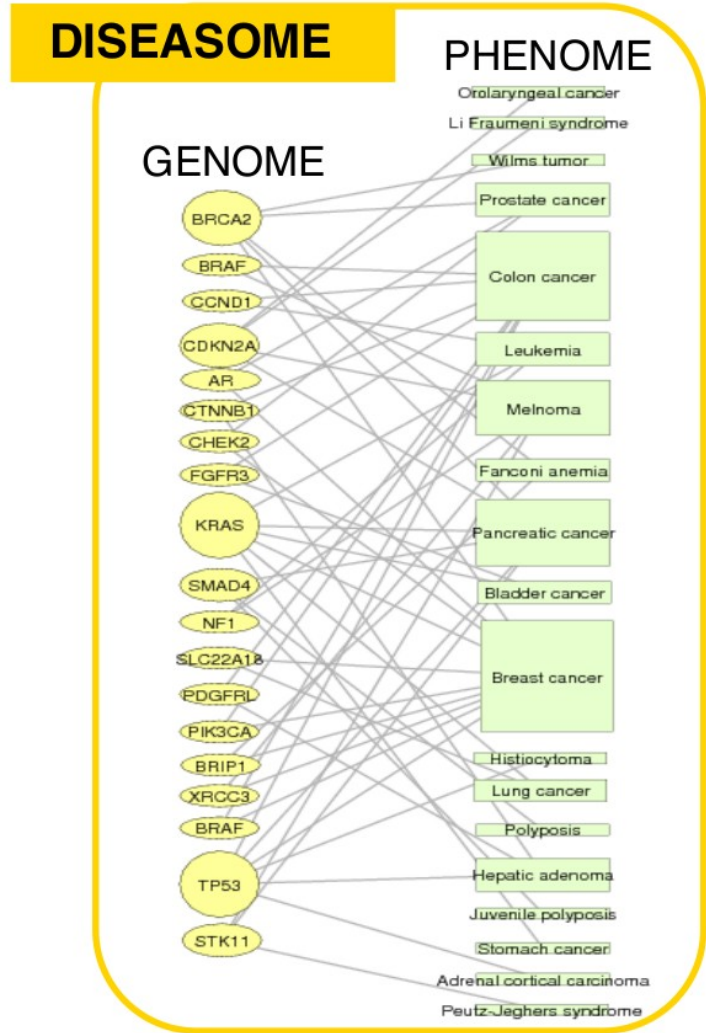

**Disease network**

Goh, Cusick, Valle, Childs, Vidal & Barabási, PNAS (2007)

